



Service Manual

Models: GEH12AA-K3DNA1D
GEH18AA-K3DNA1D
(Refrigerant R410A)

Table of Contents

| | |
|---|----|
| Part I : Technical Information | 1 |
| 1. Summary | 1 |
| 2. Specifications | 2 |
| 2.1 Specification Sheet..... | 2 |
| 2.2 Operation Characteristic Curve..... | 4 |
| 2.3 Capacity Variation Ratio According to Temperature..... | 5 |
| 2.4 Cooling and Heating Data Sheet in Rated Frequency..... | 6 |
| 2.5 Noise Curve..... | 6 |
| 3. Outline Dimension Diagram | 7 |
| 3.1 Indoor Unit..... | 7 |
| 3.2 Outdoor Unit..... | 8 |
| 4. Refrigerant System Diagram | 9 |
| 5. Electrical Part | 10 |
| 5.1 Wiring Diagram..... | 10 |
| 5.2 PCB Printed Diagram..... | 12 |
| 6. Function and Control | 15 |
| 6.1 Remote Controller Introduction..... | 15 |
| 6.2 Operation of Smart Control (Smart Phone, Tablet PC)..... | 19 |
| 6.3 Operation of Smart Control (Smart Phone, Tablet PC) For Gree..... | 30 |
| 6.4 Brief Description of Modes and Functions..... | 41 |
| Part II : Installation and Maintenance | 43 |
| 7. Notes for Installation and Maintenance | 43 |
| 8. Installation | 45 |
| 8.1 Requirements for Electric Connection..... | 45 |
| 8.2 Installation of indoor unit..... | 45 |
| 8.3 Outdoor Unit Installation..... | 51 |
| 8.4 Vacuum Pumping and Leak Detection..... | 52 |
| 8.5 Check after Installation and Test Operation..... | 53 |
| 9. Maintenance | 54 |
| 9.1 Error Code List..... | 54 |
| 9.2 Troubleshooting for Main Malfunction..... | 56 |
| 9.3 Maintenance Method for Normal Malfunction..... | 61 |

| | |
|---|--------|
| 10. Exploded View and Parts List | 63 |
| 10.1 Indoor Unit..... | 63 |
| 10.2 Outdoor Unit..... | 65 |
| 11. Removal Procedure | 69 |
| 11.1 Removal Procedure of Indoor Unit | 69 |
| 11.2 Removal Procedure of Outdoor Unit | 73 |
| Appendix: | 85 |
| Appendix 1: Reference Sheet of Celsius and Fahrenheit | 85 |
| Appendix 2: Configuration of Connection Pipe..... | 85 |
| Appendix 3: Pipe Expanding Method | 86 |
| Appendix 4: List of Resistance for Temperature Sensor | 87 |

Part I : Technical Information

1. Summary

Indoor Unit

GEH12AA-K3DNA1D/I
GEH18AA-K3DNA1D/I



Outdoor Unit

GEH12AA-K3DNA1D/O(LCLH)

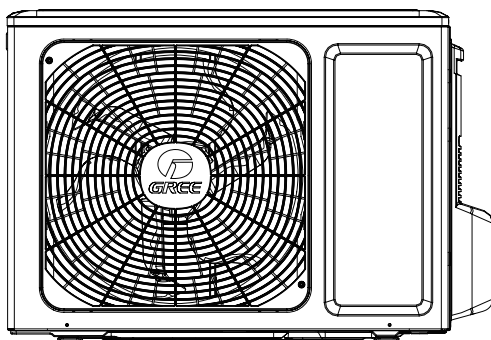

GEH18AA-K3DNA1D/O(LCLH)

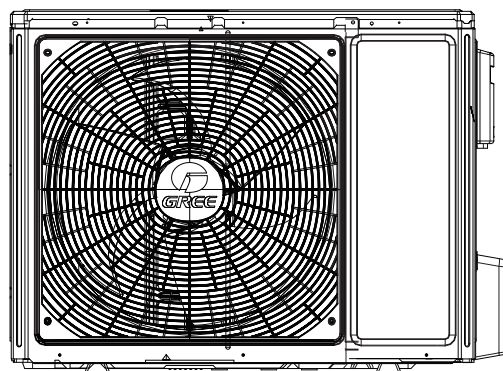

Remote Controller

YAA1FB8(WiFi)



2. Specifications

2.1 Specification Sheet

| Parameter | | Unit | Value | |
|------------------------------------|--|-------------------|--|--|
| Model | | | GEH12AA-K3DNA1D | GEH18AA-K3DNA1D |
| Product Code | | | CV010002600 | CV010002400 |
| Power Supply | Rated Voltage | V ~ | 220-240 | 220-240 |
| | Rated Frequency | Hz | 50 | 50 |
| | Phases | | 1 | 1 |
| Power Supply Mode | | | Outdoor | Outdoor |
| Cooling Capacity(Min~Max) | | W | 3500 | 5200 |
| Heating Capacity(Min~Max) | | W | 3750 | 5330 |
| Cooling Power Input(Min~Max) | | W | 1100 | 1600 |
| Heating Power Input(Min~Max) | | W | 1000 | 1500 |
| Cooling Current Input | | A | 4.85 | 7.10 |
| Heating Current Input | | A | 4.33 | 6.65 |
| Rated Input | | W | 1600 | 2500 |
| Rated Current | | A | 5.9 | 10.9 |
| Air Flow Volume(SH/H/HM/M/LM/L/SL) | | m ³ /h | 600/520/480/440/400/360/280 | 700/650/580/520/460/410/320 |
| Dehumidifying Volume | | L/h | 1.2 | 1.8 |
| EER | | W/W | 3.18 | 3.25 |
| COP | | W/W | 3.75 | 3.55 |
| SEER | | W/W | 6.4 | 6.5 |
| HSPF | | W/W | / | / |
| Application Area | | m ² | 16-24 | 23-34 |
| Indoor Unit | Indoor Unit Model | | GEH12AA-K3DNA1D/I | GEH18AA-K3DNA1D/I |
| | Indoor Unit Product Code | | CV010N02600 | CV010N02400 |
| | Fan Type | | Centrifugal | Centrifugal |
| | Fan Diameter Length(DXL) | mm | Φ370X80 | Φ370X80 |
| | Cooling Speed (SH/H/HM/M/LM/L/SL) | r/min | 750/650/600/550/500/450/350 720/620/570/520/470/420/320 | 840/800/720/650/580/530/410 810/770/690/620/550/500/380 |
| | Heating Speed (SH/H/HM/M/LM/L/SL) | r/min | 750/650/600/550/500/450/350 720/620/570/520/470/420/320 | 930/840/760/690/620/570/480 850/800/720/650/580/530/470 |
| | Fan Motor Power Output | W | 30 | 30 |
| | Fan Motor RLA | A | 0.15 | 0.15 |
| | Fan Motor Capacitor | μF | / | / |
| | Evaporator Form | | Aluminum Fin-copper Tube | Aluminum Fin-copper Tube |
| | Evaporator Pipe Diameter | mm | Φ7 | Φ7 |
| | Evaporator Row-fin Gap | mm | 2-1.3 | 2-1.3 |
| | Evaporator Coil Length (LXDXW) | mm | 511X400X25.4 | 511X400X25.4 |
| | Swing Motor Model | | MP24EB/MP24AE | MP24EB/MP24AE |
| | Swing Motor Power Output | W | 1.5/1.5 | 1.5/1.5 |
| | Fuse Current | A | 3.15 | 3.15 |
| | Sound Pressure Level (SS/H/MH/M/ML/L/SL) | dB (A) | 42/40/38/36/34/31/25 | 47/45/42/40/37/35/31 |
| | Sound Power Level (SS/H/MH/M/ML/L/SL) | dB (A) | 52/50/48/46/44/41/35 | 57/55/52/50/47/45/41 |
| | Dimension (WXHXD) | mm | 700X215X600 | 700X215X600 |
| | Dimension of Carton Box (LXWXH) | mm | 785X280X682 | 785X280X682 |
| | Dimension of Package(LXWXH) | mm | 788X283X697 | 788X283X697 |
| Net Weight | kg | 15.5 | 15.5 | |
| Gross Weight | kg | 18.5 | 18.5 | |

| | | | | |
|--|---|-------------------|--|--|
| Outdoor Unit | Outdoor Unit Model | | GEH12AA-K3DNA1D/O | GEH18AA-K3DNA1D/O |
| | Outdoor Unit Product Code | | CV010W02600 | CV010W02400 |
| | Compressor Manufacturer | | ZHUHAI LANDA COMPRESSOR CO.,LTD | ZHUHAI LANDA COMPRESSOR CO.,LTD |
| | Compressor Model | | QXA-B102zE190 | QXA-B141zF030 |
| | Compressor Oil | | RB68EP | 68EP |
| | Compressor Type | | Rotary | Rotary |
| | Compressor LRA | A | / | 18 |
| | Compressor RLA | A | 6.6 | 7.2 |
| | Compressor Power Input | W | 1020 | 1440 |
| | Compressor Overload Protector | | 1NT11L-6233 or HPC115/95U1 or KSD115°C | 1NT11L-6233 or KSD115°C or HPC115/95U1 |
| | Throttling Method | | Electron expansion valve | Electron expansion valve |
| | Set Temperature Range | °C | 16~30 | 16~30 |
| | Cooling Operation Ambient Temperature Range | °C | -15~43 | -15~43 |
| | Heating Operation Ambient Temperature Range | °C | -22~24 | -22~24 |
| | Condenser Form | | Aluminum Fin-copper Tube | Aluminum Fin-copper Tube |
| | Condenser Pipe Diameter | mm | Φ7.94 | Φ7 |
| | Condenser Rows-fin Gap | mm | 2-1.4 | 2-1.4 |
| | Condenser Coil Length (LXDXW) | mm | 710X38.1X508 | 851X38.1X660 |
| | Fan Motor Speed | rpm | 900 | 800 |
| | Fan Motor Power Output | W | 30 | 60 |
| | Fan Motor RLA | A | 0.37 | 0.39 |
| | Fan Motor Capacitor | μF | / | / |
| | Outdoor Unit Air Flow Volume | m ³ /h | 1600 | 3200 |
| | Fan Type | | Axial-flow | Axial-flow |
| | Fan Diameter | mm | Φ400 | Φ520 |
| | Defrosting Method | | Automatic Defrosting | Automatic Defrosting |
| | Climate Type | | T1 | T1 |
| | Isolation | | I | I |
| | Moisture Protection | | IPX4 | IPX4 |
| | Permissible Excessive Operating Pressure for the Discharge Side | MPa | 4.3 | 4.3 |
| | Permissible Excessive Operating Pressure for the Suction Side | MPa | 2.5 | 2.5 |
| | Sound Pressure Level (H/M/L) | dB (A) | 52/-/- | 57/-/- |
| Sound Power Level (H/M/L) | dB (A) | 62/-/- | 65/-/- | |
| Dimension(WXHXD) | mm | 782X540X320 | 963X700X396 | |
| Dimension of Carton Box (LXWXH) | mm | 820X355X580 | 1026X455X735 | |
| Dimension of Package(LXWXH) | mm | 823X358X595 | 1029X458X750 | |
| Net Weight | kg | 31.5 | 46 | |
| Gross Weight | kg | 34 | 50.5 | |
| Refrigerant | | R410A | R410A | |
| Refrigerant Charge | kg | 0.95 | 1.3 | |
| Connection Pipe | Connection Pipe Length | m | 5 | 5 |
| | Connection Pipe Gas Additional Charge | g/m | 20 | 20 |
| | Outer Diameter Liquid Pipe | mm | Φ6 | Φ6 |
| | Outer Diameter Gas Pipe | mm | Φ9.52 | Φ12 |
| | Max Distance Height | m | 10 | 10 |
| | Max Distance Length | m | 20 | 25 |
| Note: The connection pipe applies metric diameter. | | | | |

The above data is subject to change without notice. Please refer to the nameplate of the unit.

2.2 Operation Characteristic Curve

12K

Cooling

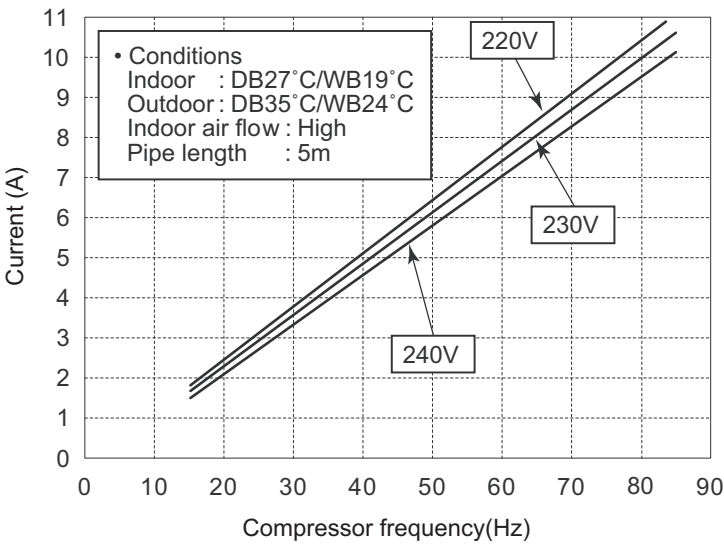

Heating

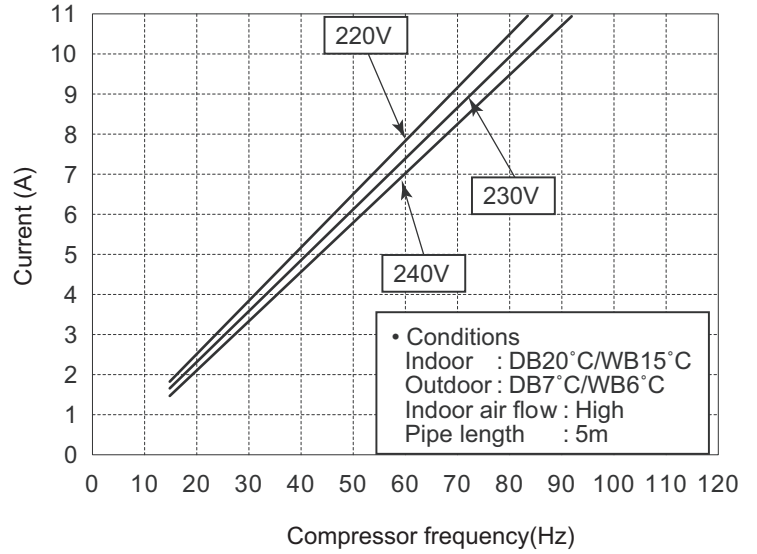

18K

Cooling

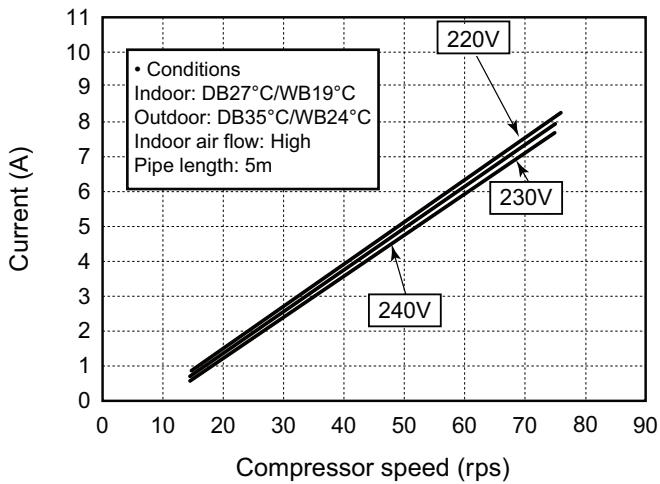

Heating

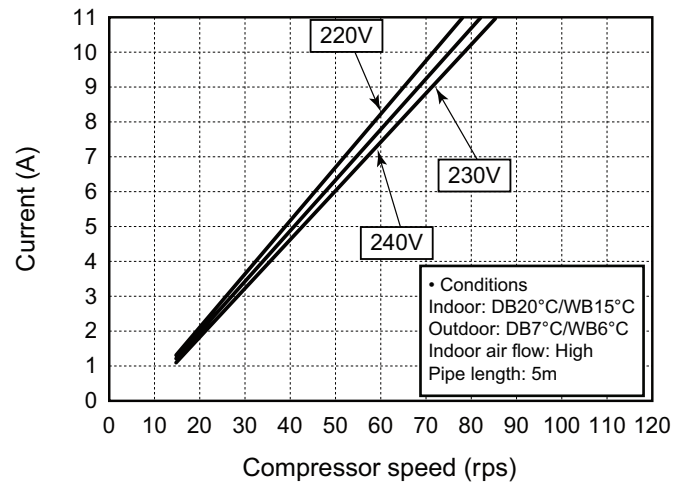

2.3 Capacity Variation Ratio According to Temperature

12K

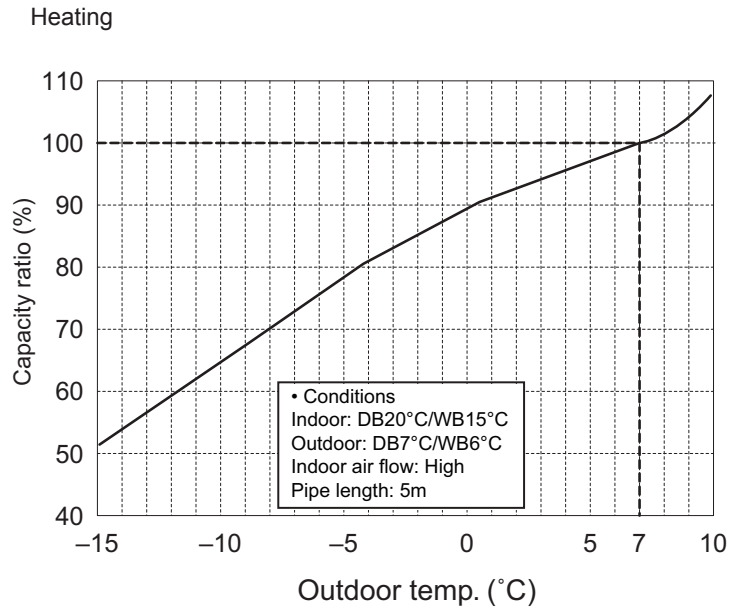
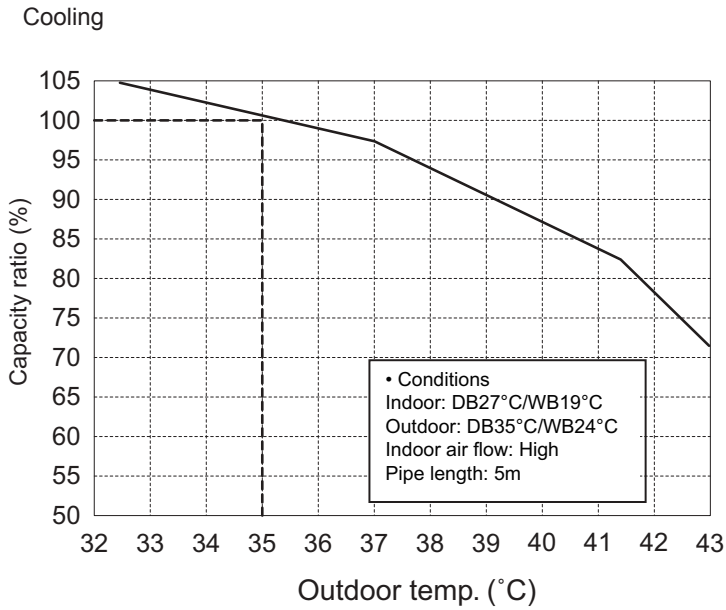

18K

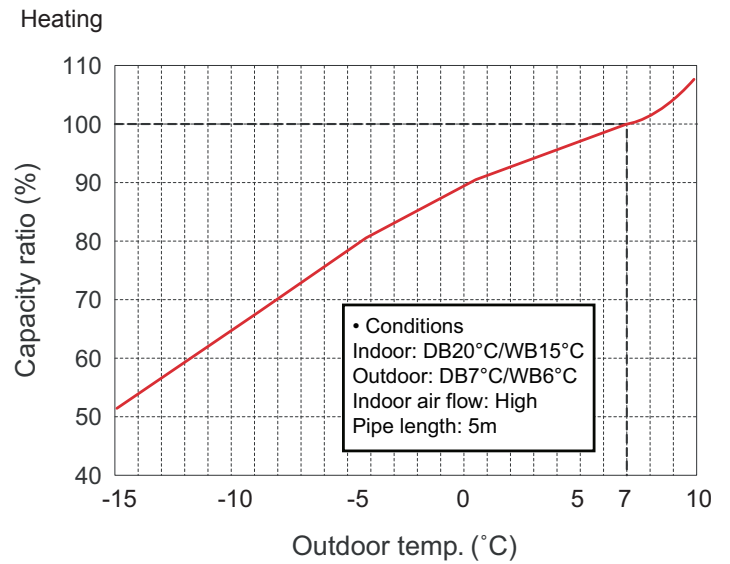
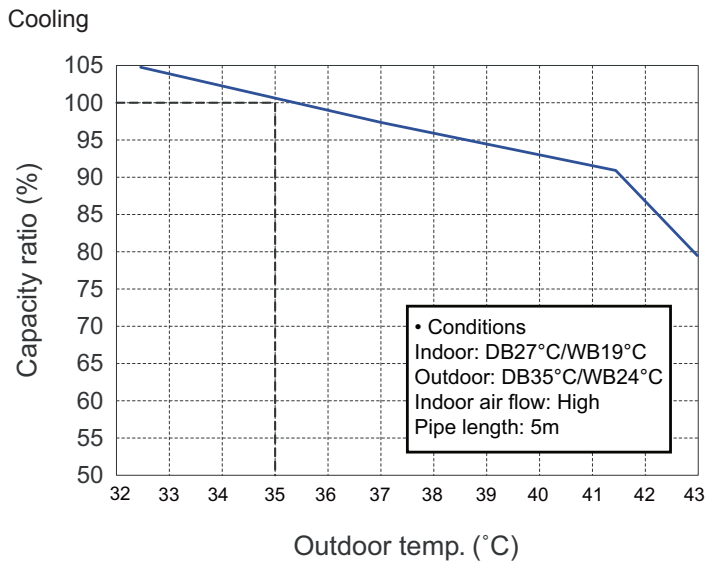

2.4 Cooling and Heating Data Sheet in Rated Frequency

Cooling:

| Rated cooling condition(°C) (DB/WB) | | Model | Pressure of gas pipe connecting indoor and outdoor unit | Inlet and outlet pipe temperature of heat exchanger | | Fan speed of indoor unit | Fan speed of outdoor unit | Compressor frequency (Hz) |
|--|---------|-------|---|---|----------|-----------------------------|------------------------------|---------------------------------|
| Indoor | Outdoor | | | T1 (°C) | T2 (°C) | | | |
| 27/19 | 35/24 | 12K | 0.9 to 1.1 | 12 to 14 | 70 to 40 | Super High | High | 72 |
| | | 18K | | 12 to 14 | 80 to 40 | Super High | High | 70 |

Heating:

| Rated heating condition(°C) (DB/WB) | | Model | Pressure of gas pipe connecting indoor and outdoor unit | Inlet and outlet pipe temperature of heat exchanger | | Fan speed of indoor unit | Fan speed of outdoor unit | Compressor frequency (Hz) |
|--|---------|-------|---|---|---------|-----------------------------|------------------------------|---------------------------------|
| Indoor | Outdoor | | | T1 (°C) | T2 (°C) | | | |
| 20/- | 7/6 | 12K | 2.2 to 2.4 | 70 to 35 | 2 to 4 | Super High | High | 77 |
| | | 18K | | 70 to 40 | 1 to 5 | Super High | High | 70 |

Instruction:

T1: Inlet and outlet pipe temperature of evaporator

T2: Inlet and outlet pipe temperature of condenser

P: Pressure at the side of big valve

Connection pipe length: 5 m.

2.5 Noise Curve

12K

Indoor side noise when blowing

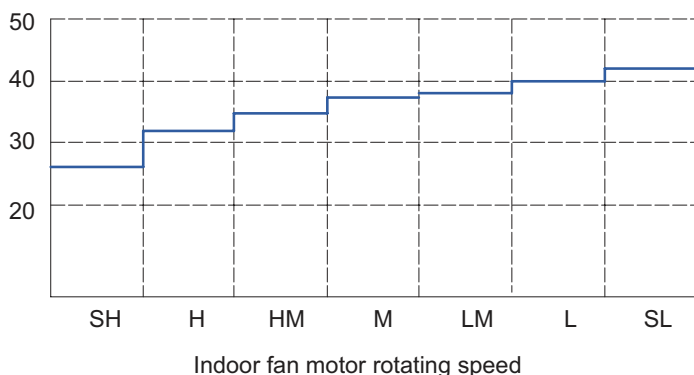

Outdoor side noise when blowing

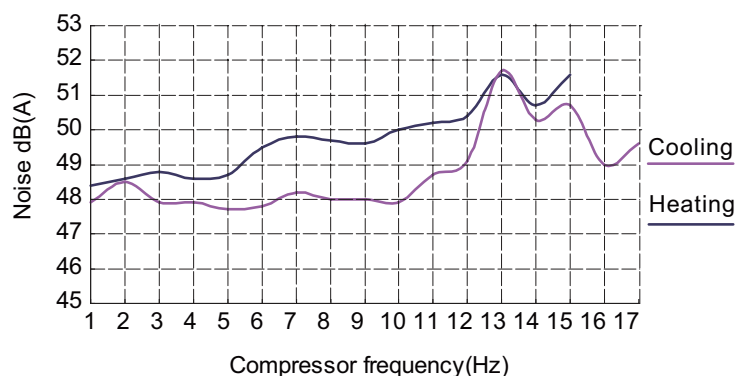

18K

Indoor side noise when blowing

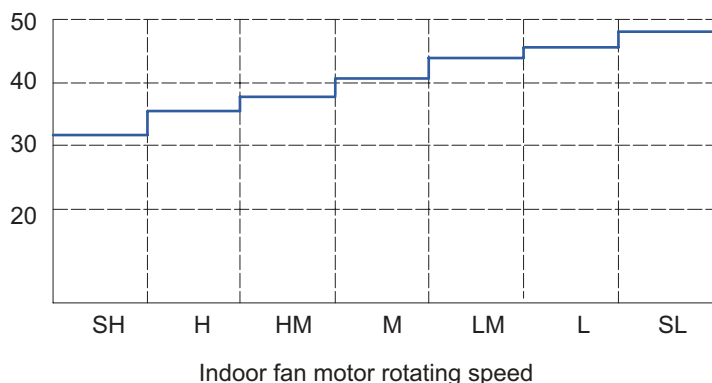

Outdoor side noise when blowing

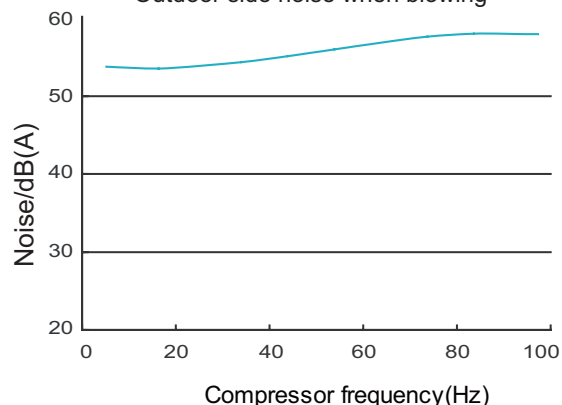

3. Outline Dimension Diagram

3.1 Indoor Unit

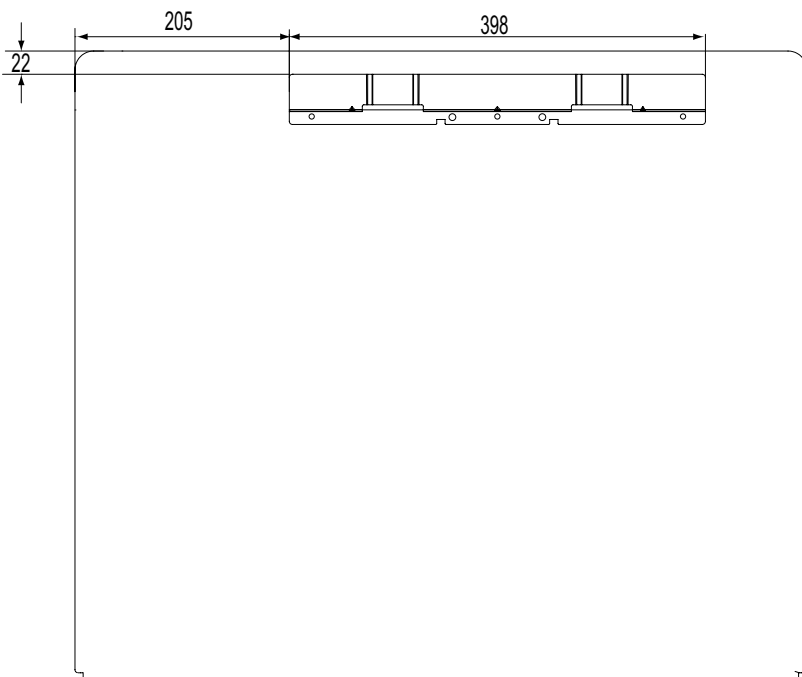
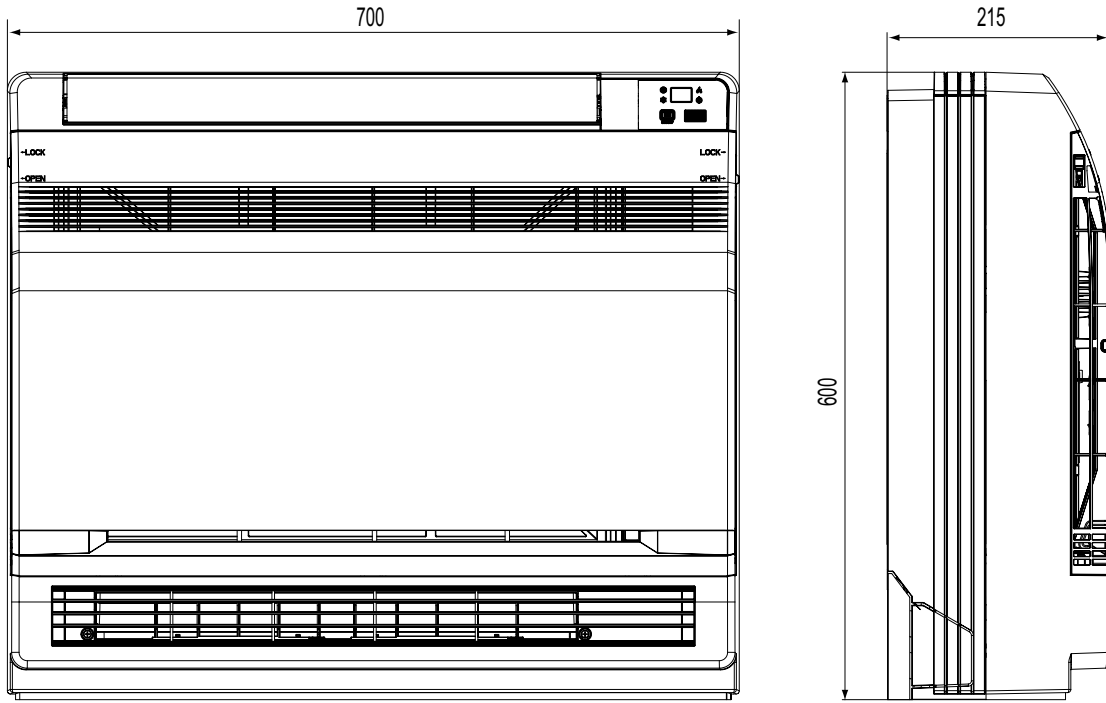

Unit:mm

3.2 Outdoor Unit

12K

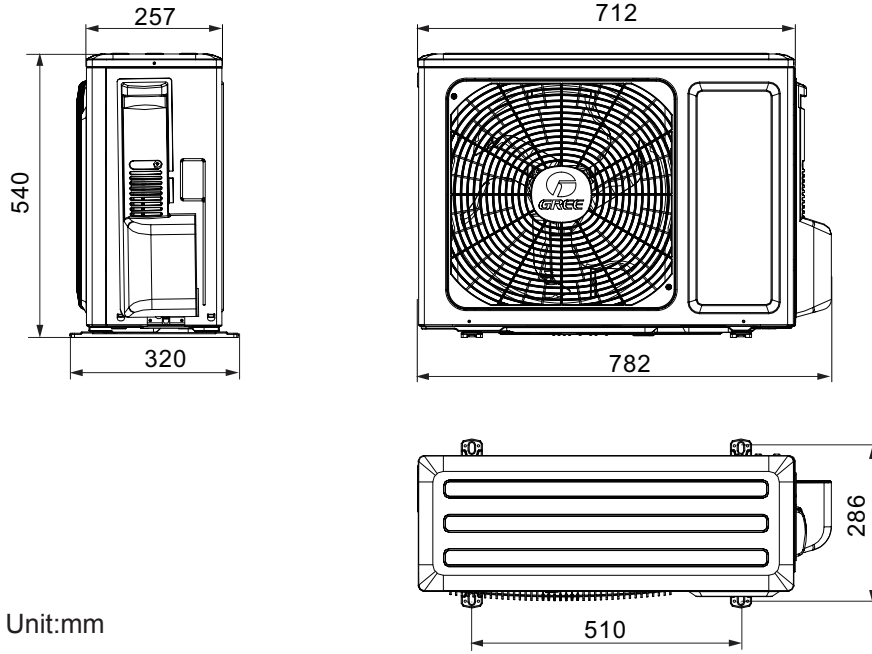

Unit:mm

18K

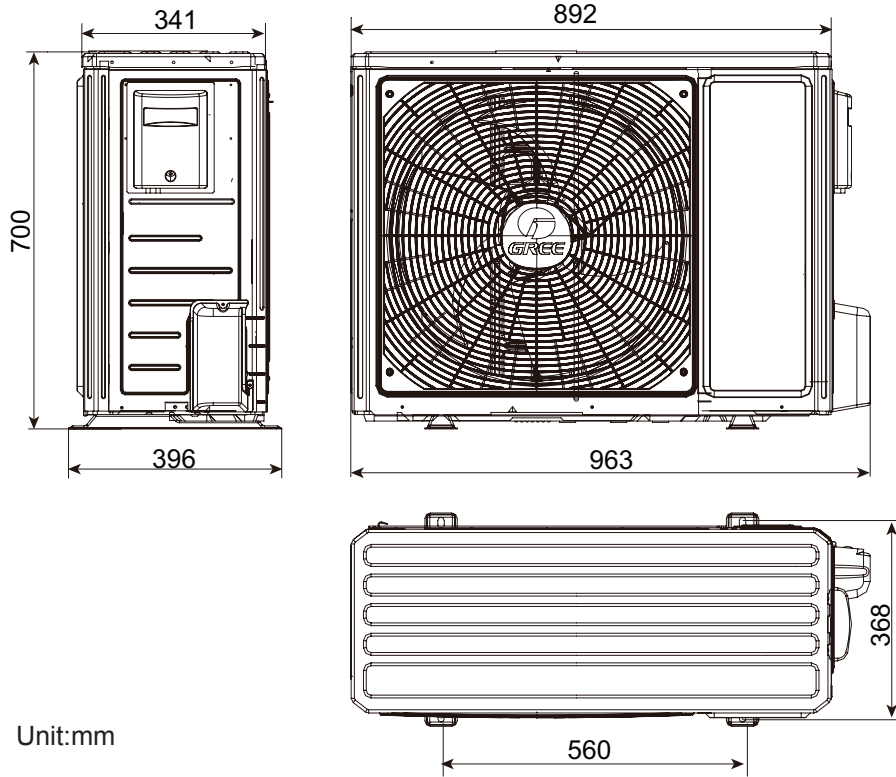

Unit:mm

5. Electrical Part

5.1 Wiring Diagram

• Instruction

| Symbol | Symbol Color | Symbol | Symbol Color | Symbol | Name |
|--------|--------------|--------|--------------|--------|----------------|
| WH | White | GN | Green | CAP | Jumper cap |
| YE | Yellow | BN | Brown | COMP | Compressor |
| RD | Red | BU | Blue | ⊕ | Grounding wire |
| YEGN | Yellow/Green | BK | Black | / | / |
| VT | Violet | OG | Orange | / | / |

Note: Jumper cap is used to determine fan speed and the swing angle of horizontal lover for this model.

• Indoor Unit

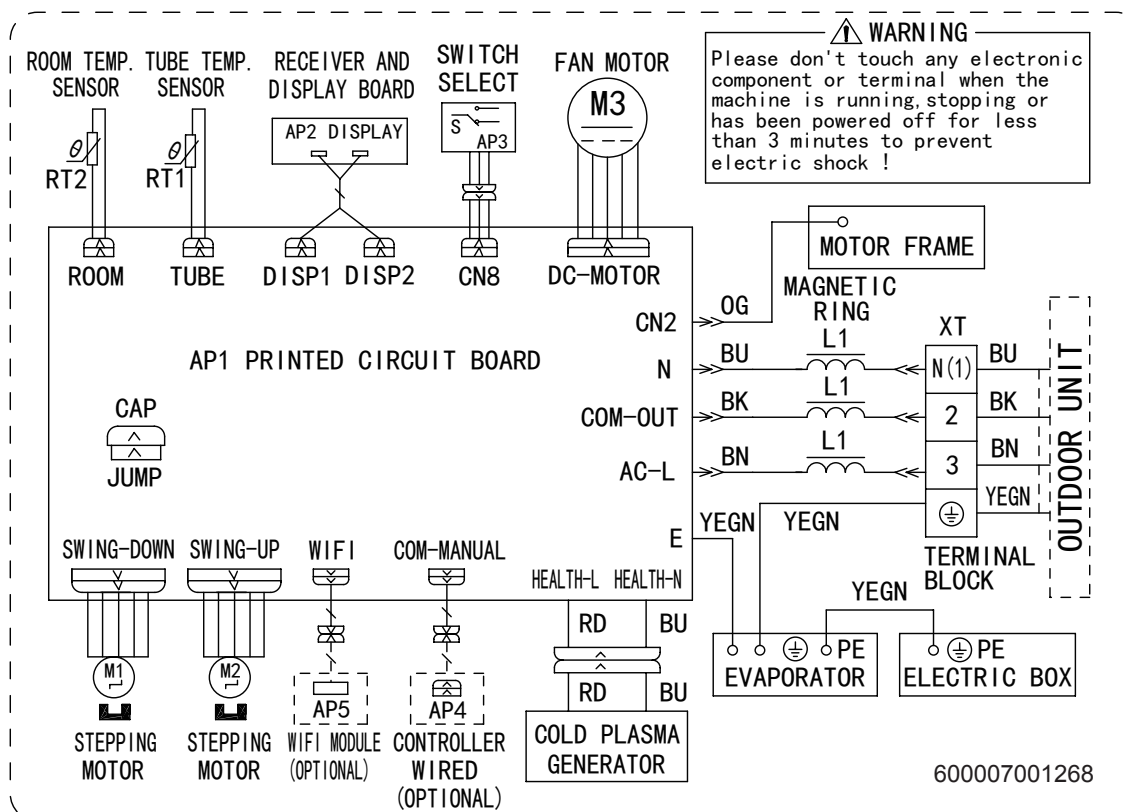

• Outdoor Unit

12K

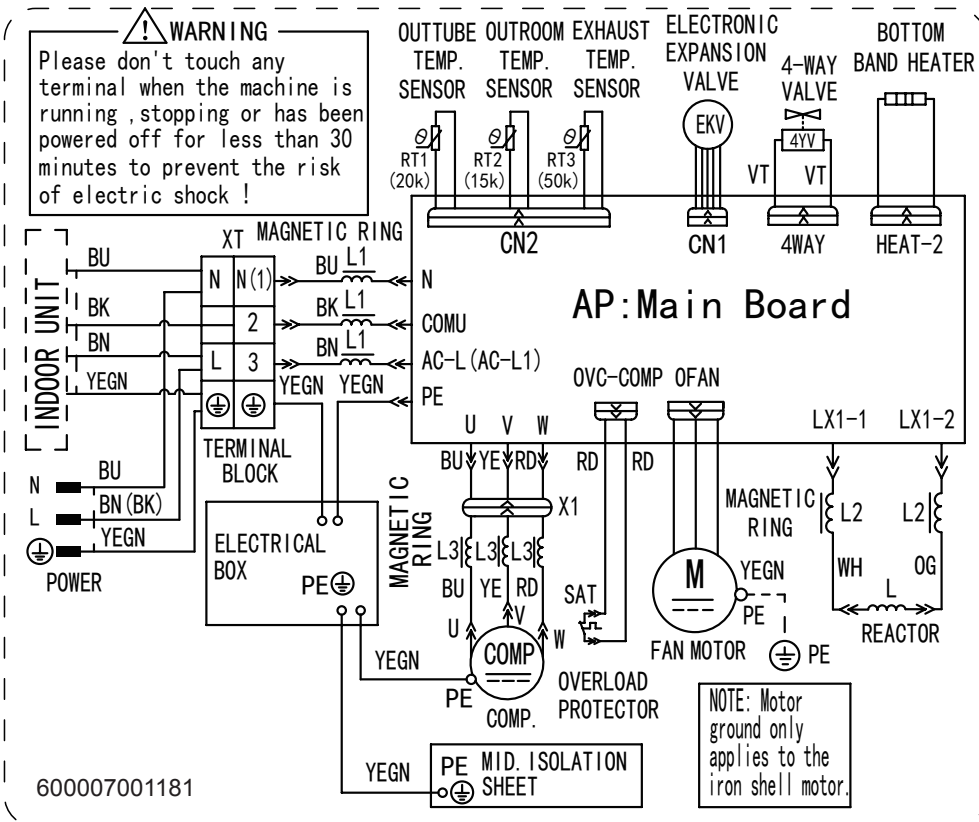

18K

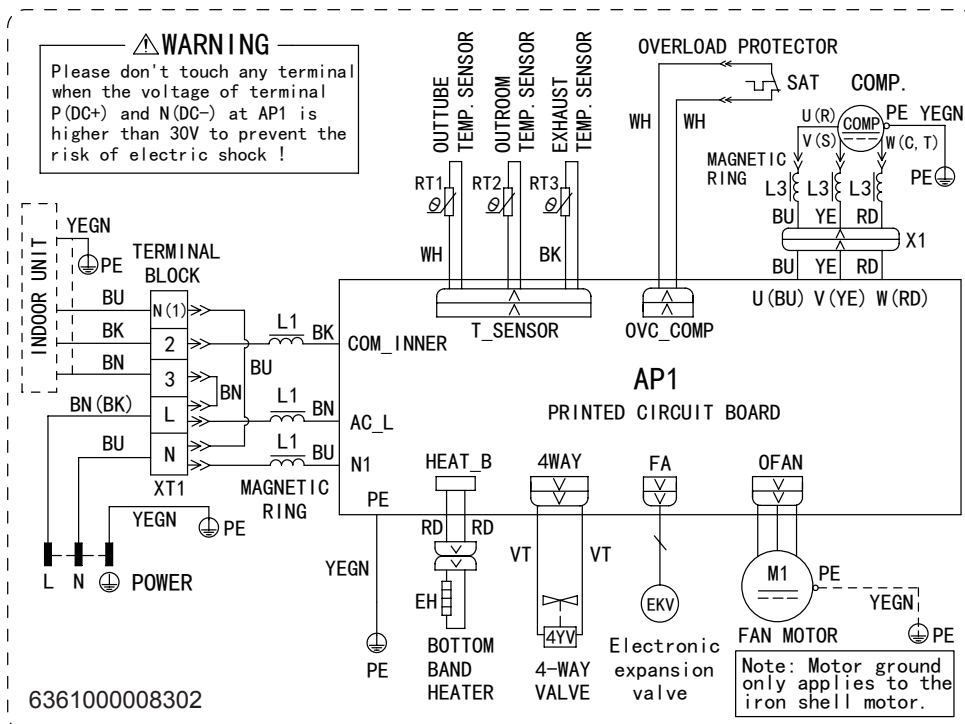

These circuit diagrams are subject to change without notice, please refer to the one supplied with the unit.

5.2 PCB Printed Diagram

Indoor Unit

● Top view

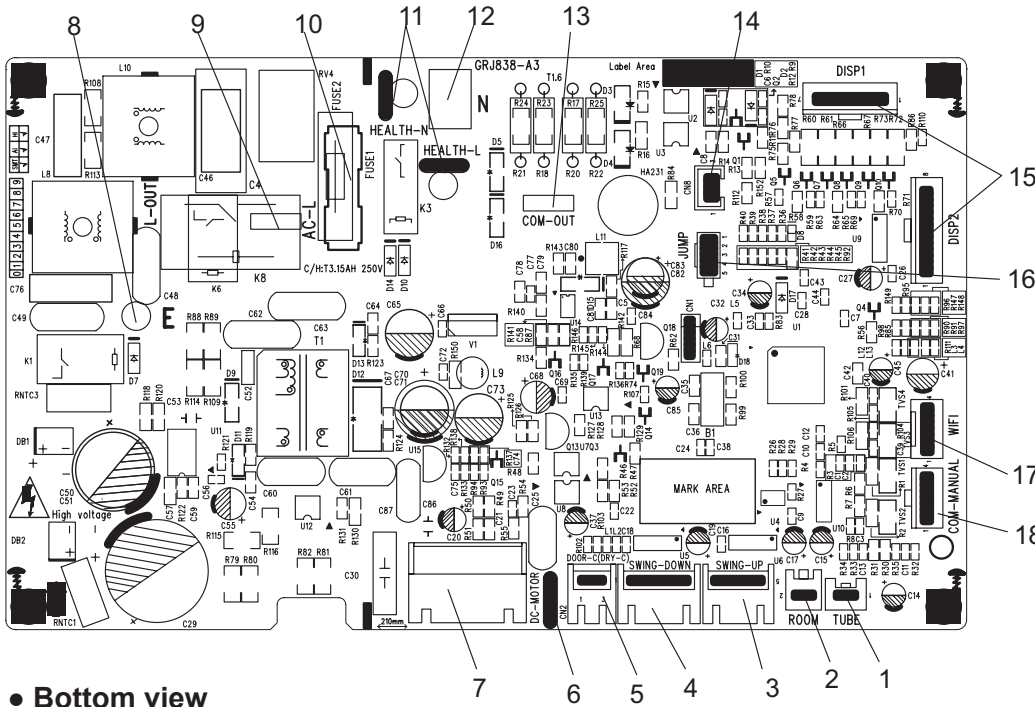

● Bottom view

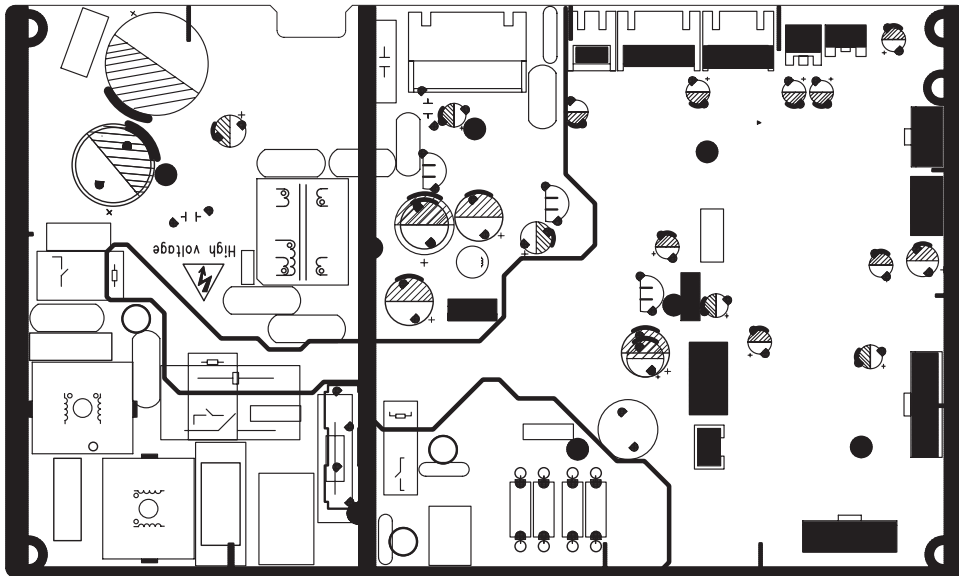

| NO. | Name |
|-----|--|
| 1 | Interface of tube temperature sensor |
| 2 | Interface of ambient temperature sensor |
| 3 | Up swing interface |
| 4 | Down swing interface |
| 5 | Door control interface (this is only for the model with this function) |
| 6 | Interface of EMC shielding wire |
| 7 | DC motor interface |
| 8 | Earthing wire of main board |
| 9 | Terminal of live wire |
| 10 | Fuse |
| 11 | Terminal for health function |
| 12 | Terminal of neutral wire |
| 13 | Communication interface between indoor unit and outdoor unit |
| 14 | Control interface of Down swing |
| 15 | Interface of display board |
| 16 | Needle stand of jumper cap |
| 17 | WIFI interface |
| 18 | Wired controlled interface |

Outdoor Unit

12K

• Top view

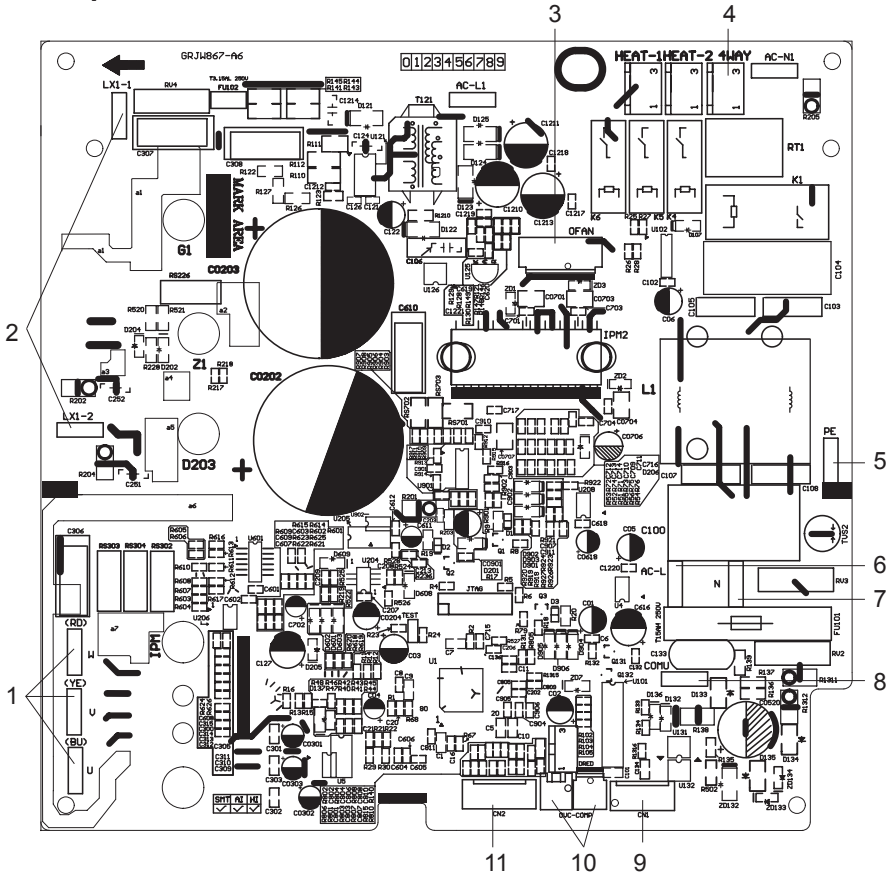

| | |
|----|--|
| 1 | Compressor UVW three phase input interface |
| 2 | Interface of reactor |
| 3 | Interface of fan |
| 4 | 4-way valve |
| 5 | Interface of earthing wire |
| 6 | Interface of live wire |
| 7 | Interface of neutral wire |
| 8 | Interface of communication |
| 9 | Interface of electronic expansion valve |
| 10 | Overload interface of compressor |
| 11 | Interface of temperature sensor |

• Bottom view

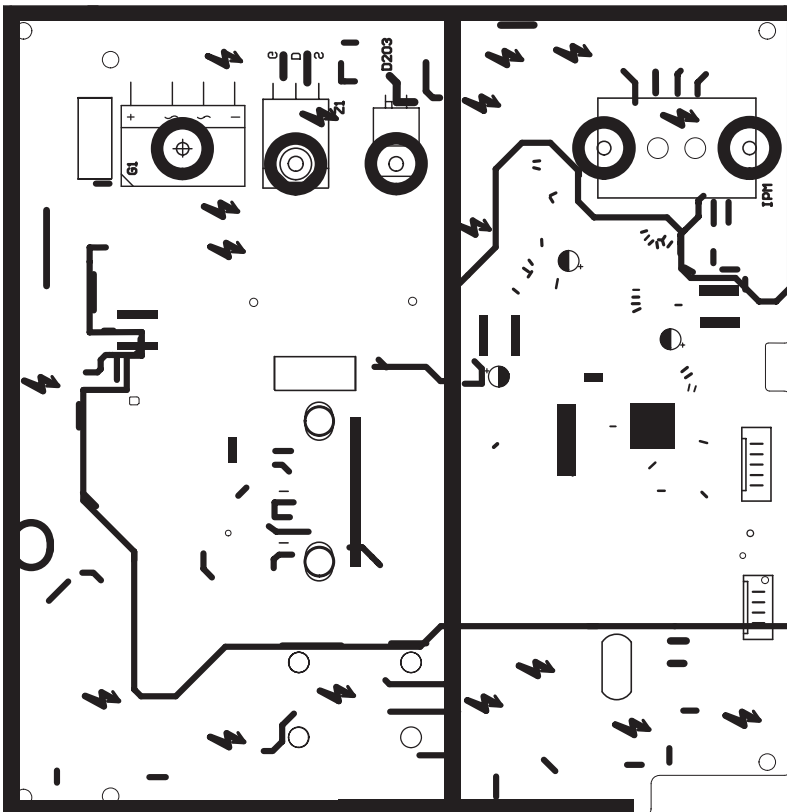

18K

• Top view

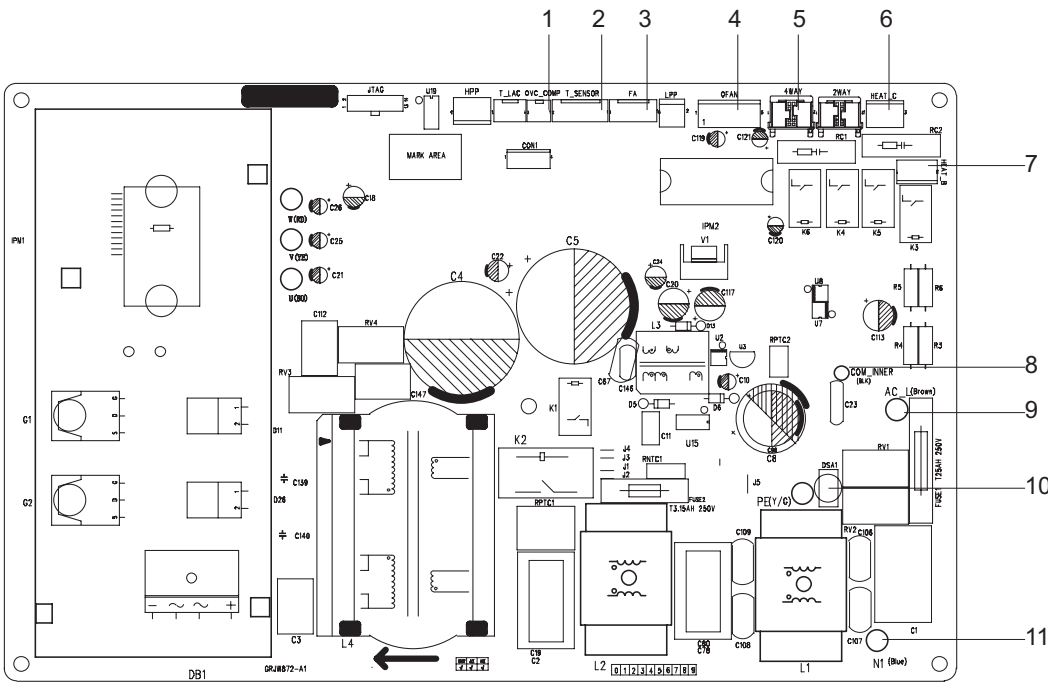

| NO. | Name |
|-----|--|
| 1 | Terminal of compressor overload protection |
| 2 | Terminal of temperature sensor |
| 3 | Terminal of electronic expansion valve |
| 4 | Terminal of outdoor fan |
| 5 | Terminal of 4-way valve |
| 6 | Terminal of compressorelectric heating |
| 7 | Terminal of chassis electric heating |
| 8 | Terminal of indoor unit and outdoor unit communication |
| 9 | Power supply live wire |
| 10 | Earthing wire |
| 11 | Power supply neutral wire |

• Bottom view

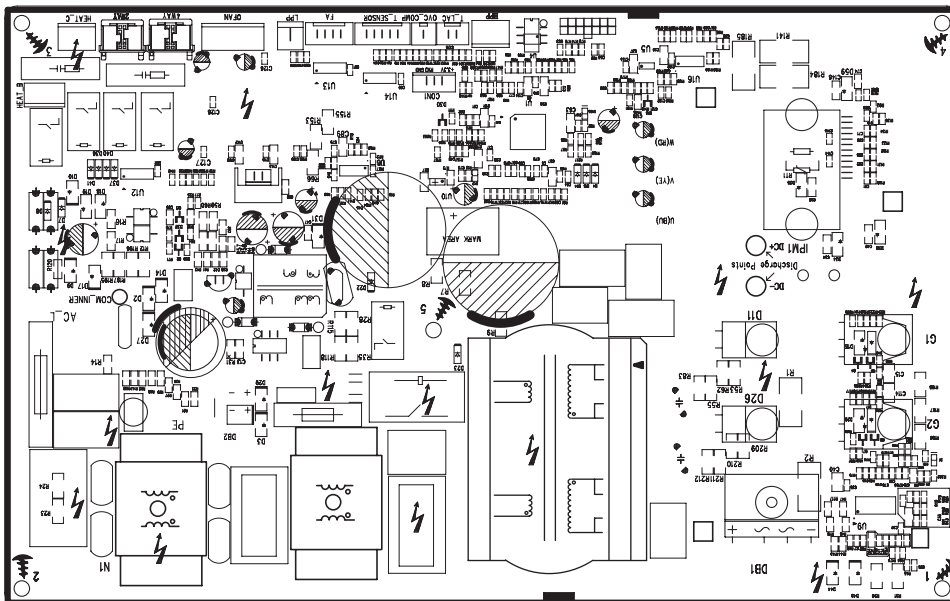

3 MODE button

Each time you press this button, a mode is selected in a sequence that goes from AUTO, COOL, DRY, FAN, and HEAT*, as the following:



*Note: Only for models with heating function.

After energization, AUTO mode is defaulted. In AUTO mode, the set temperature will not be displayed on the LCD, and the unit will automatically select the suitable operation mode in accordance with the room temperature to make indoor room comfortable. (As for cooling only unit, it won't have any action when it receives the signal of heating operation.)

4 FAN button

This button is used for setting Fan Speed in the sequence that goes from AUTO, , , to , then back to Auto.

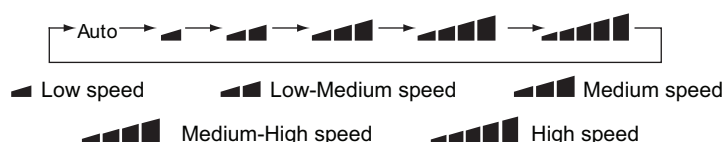

5 SWING button

Press this button to set up & down swing angle, which circularly changes as below:



This remote controller is universal. If any command , or is sent out, the unit will carry out the command as indicates the guide louver swings as:

6 I FEEL button

Press this button to turn on I FEEL function. The unit automatically adjust temperature according to the sensed temperature. Press this button again to cancel I FEEL function.

7 button

Press this button to achieve the on and off of healthy and scavenging functions in operation status. Press this button for the first time to start scavenging function; LCD displays "". Press the button for the second time to start healthy and scavenging functions simultaneously; LCD displays "" and "". Press this button for the third time to quit healthy and scavenging functions simultaneously. Press the button for the fourth time to start healthy function; LCD display "". Press this button again to repeat the operation above.

8 SLEEP button

- Press this button, can select Sleep 1 (), Sleep 2 (), Sleep 3 () and cancel the Sleep, circulate between these, after electrified, Sleep Cancel is defaulted.
- Sleep 1 is Sleep mode 1, in Cool mode: after run for one hour in sleep mode, the main unit setting temperature will increase 1°C, after 2 hours, the setting temperature will increase 2°C, but the maximal setting temperature is 30°C, then the unit will run at this setting temperature all along; In Heat mode: after run for one hour in sleep mode, the setting temperature will decrease 1°C after 2 hours the setting temperature will decrease 2°C, but the minimal setting temperature is 16°C, then the unit will run at this setting temperature all along.
- Sleep 2 is sleep mode 2, that is air conditioner will run according to the presetting a group of sleep temperature curve.
- Sleep 3- the sleep curve setting under Sleep mode by DIY:

- (1) Under Sleep 3 mode, press "Turbo" button for a long time, remote control enters into user individuation sleep setting status, at this time, the time of remote control will display "1hour ",the setting temperature "88" will display the corresponding temperature of last setting sleep curve and blink (The first entering will display according to the initial curve setting value of original factory);
- (2) Adjust "+" and "-" button, could change the corresponding setting temperature, after adjusted, press "Trubo "button for confirmation;
- (3) At this time, 1hour will be automatically increased at the timer position on the remote control, (that are "2hours " or "3hours " or "8hours "), the place of setting temperature "88" will display the corresponding temperature of last setting sleep curve and blink;
- (4) Repeat the above step (2) ~ (3) operation, until 8hours temperature setting finished,sleep,curve setting finished, at this time, the remote control will resume the original timer display;temperature display will resume to original setting temperature.



Sleep3- the sleep curve setting under Sleep mode by DIY could be inquired:

- The user could accord to sleep curve setting method to inquire the presetting sleep curve,enter into user individuation sleep setting status, but do not change the temperature, press "Turbo" button directly for confirmation.Note: In the above presetting or enquiry procedure,if continuously within10s, there is no button pressed, the sleep curve setting within 10s, there is no button pressed , the sleep curve setting status will be automatically quit and resume to display the original displaying. In the presetting or enquiry procedure, press "ON/OFF" button, "Mode" button, "Timer"button or "Sleep" button, the sleep curve setting or enquiry status will quit similarly.

9 TEMP button

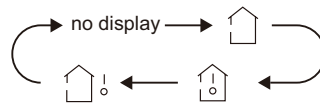
Press this button, you can see indoor set temperature, indoor ambient temperature on indoor unit's display. The setting on remote controller is selected circularly as below:







When selecting "  " with remote controller or no display, temperature indicator on indoor unit displays set temperature; When selecting "  " with remote controller, temperature indicator on indoor unit displays indoor ambie nt temperature; 5s later or within 5s it receives other remote control signal that will return to display the setting temperature.



Caution:

- This model hasn't outdoor ambient temperature display function. While remote controller can operate "  " and indoor unit displays set temperature.
- It's defaulted to display set temperature when turning on the unit.
- Only for the models with temperature indicator on indoor unit.

10 QUIET button

Press this button, the Quiet status is under the Auto Quiet mode (display "  "signal)and Quiet mode (display "  " singal) and Quiet OFF (there is no signal of "  "displayed),after powered on, the Quiet OFF is defaulted. Note: the Quiet function cannot be set up in Fan and Dry mode;Under the Quiet mode (Display"  " Under the Quiet mode) the fan speed is not available.

11 CLOCK button

Press CLOCK button,blinking.  Within 5 seconds, pressing + or - button adjusts the present time. Holding down either button above 2 seconds increases or decreases the time by 1 minute every 0.5 second and then by 10 minutes every 0.5 second. During blinking after setting, press CLOCK button again to confirm the setting, and  then will be constantly displayed.

12 T-ON/T-OFF button

Press T-ON button to initiate the auto-ON timer. To cancel the auto-timer program, simply press this button again.

After press of this button,  disappears and "ON "blink s . 00:00 is displayed for ON time setting. Within 5 seconds, press + or - button to adjust the time value. Every press of either button changes the time setting by 1 minute. Holding down either button rapidly changes the time setting by 1 minute and then 10 minutes. Within 5 Seconds after setting, press TIMER ON button to confirm.

Press T-OFF button to initiate the auto-off timer. To cancel the auto-timer program, simply press the button again.TIMER OFF setting is the same as TIMER ON.

13 TURBO button



Press this button to activate / deactivate the Turbo function which enables the unit to reach the preset temperature in the shortest time. In COOL mode, the unit will blow strong cooling air at super high fan speed. In HEAT mode, the unit will blow strong heating air at super high fan speed.

14 WiFi button



Press "WiFi" button to turn on or turn off WiFi function. When WiFi function is turned on, the "WiFi" icon will be displayed on remote controller; Under status of unit off, press "MODE" and "WiFi" buttons simultaneously for 1s, WiFi module will restore to factory default setting.

- This function is only available for some models.

15 LIGHT button

Press LIGHT button to turn on the display's light and press this button again to turn off the display's light. If the light is turned on,  is displayed. If the light is turned off,  disappears.

Combination of "+" and "-" buttons: About lock

Press "+" and "-" buttons simultaneously to lock or unlock the keypad. If the remote controller is locked,  is displayed. In this case, pressing any button,  blinks three times.

Combination of "MODE" and "-" buttons: About switch between Fahrenheit and centigrade

At unit OFF, press "MODE" and "-" buttons simultaneously to switch between °C and °F.

Combination of "TEMP" and "CLOCK" buttons: About Energy-saving Function

Press "TEMP" and "CLOCK" simultaneously in COOL mode to start energy-saving function. Nixie tube on the remote controller displays "SE". Repeat the operation to quit the function.

Combination of "TEMP" and "CLOCK" buttons: About 8°C Heating Function

Press "TEMP" and "CLOCK" simultaneously in HEAT mode to start 8°C Heating Function. Nixie tube on the remote controller displays "8" and a selected temperature of "8°C". (46°F if Fahrenheit is adopted). Repeat the operation to quit the function.

About Back-lighting Function

The unit lights for 4s when energizing for the first time, and 3s for later press.

Replacement of Batteries in Remote Controller

1. Press the back side of remote controller marked with  as shown in the fig, and then push out the cover of battery box along the arrow direction.
2. Replace two 7# (AAA 1.5V) dry batteries, and make sure the position of "+" polar and "-" polar are correct.
3. Reinstall the cover of battery box.

Note:

- During operation, point the remote control signal sender at the receiving window on indoor unit.
- The distance between signal sender and receiving window should be no more than 8m, and there should be no obstacles between them.
- Signal may be interfered easily in the room where there is fluorescent lamp or wireless telephone; remote controller should be close to indoor unit during operation.
- Replace new batteries of the same model when replacement is required.
- When you don't use remote controller for a long time, please take out the batteries.
- If the display on remote controller is fuzzy or there's no display, please replace batteries.

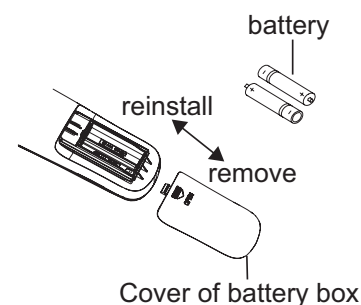

6.2 Operation of Smart Control (Smart Phone, Tablet PC)

Operation Instructions

Download and install APP

Scan the following QR code (also indicated on the package) with your smart phone and download Wifi Smart.



Install the APP according to its guidance. When successfully installed, your smart phone homepage will show this icon



Configuration

Before operation, please finish the following configuration in order to realize Wifi control and the connection between air conditioner and mobile phone.

1.Short-distance control setting for air conditioner using wifi hotspot

Step 1: Air conditioner wifi is set to AP mode in factory. You can search the air conditioner wifi hotspot through your smart phone. The name of wifi hotspot is the last 8 numbers of the air conditioner mac address. Password is 12345678.

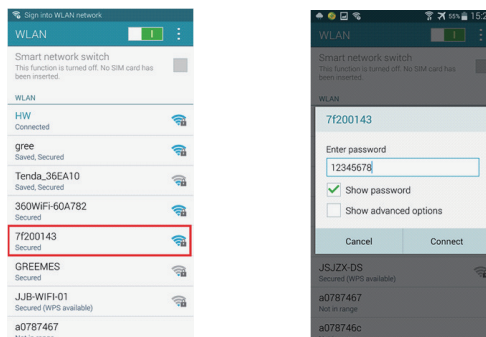

Step 2: Open Gree APP and the screen will show the air conditioner that you just connected. Click this air conditioner to enter and realize short-distance control, as shown below. Please refer to "Functions introduction" for specific control methods.

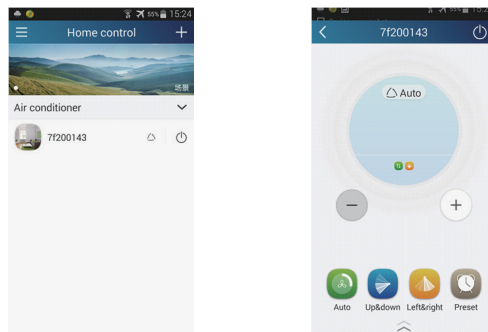

2.Short-distance and long-distance control setting for air conditioner connecting router

Step 1: Under short-distance control, return to the homepage "Home Control". Click  at the top right corner and select "Add device" to enter the page "Configure".

Step 2: Click "Manual configuration". Input router's name, password and encryption type.

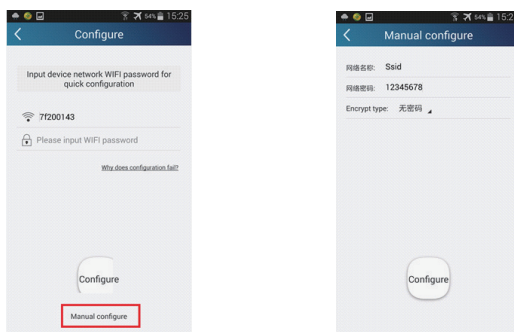

If configuration succeeds, APP will notify user that configuration is successful and displays its homepage. If configuration fails, APP will notify user that configuration fails. In this case, please repeat the above steps until the APP shows that configuration is successful.

Functions introduction

1. User registration

Purpose: To realize long-distance control

Operation instruction: For the first time login, you have to register a new username. If you already have a username, skip the registration step and input email address and password on the "Login Page" to log in. If password is forgotten, you can reset the password.

Operation steps:

(1) Login with username: Slide the "Home control" page and enter the "Menu" page on the left. Click "Login" to enter the page "Login username". New user must first register a username. Click "Register username".

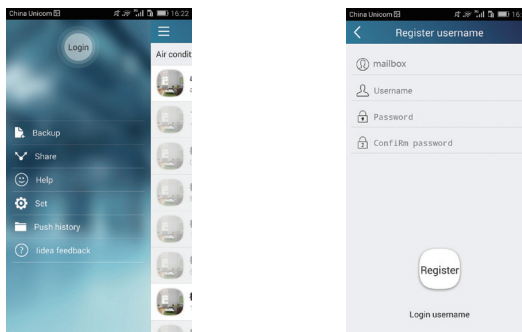

(2) Input email address and click "Get the verification code". Wait until you receive the verification code. Input the code and click "OK" to log in. Username will appear, as 3 in the picture.

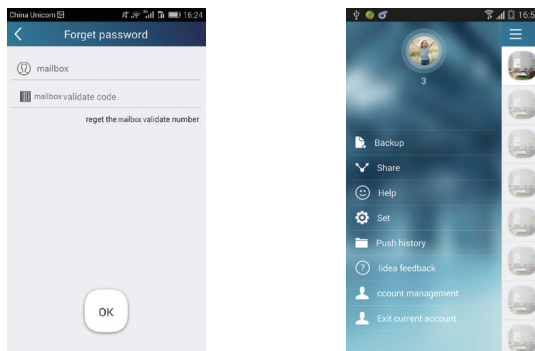

(3) If password is forgotten, you can reset the password with your phone number. Click "Forget password" and enter the page "Forget password". Click "Verification code" to get the email verification code. Input a new password and click "OK" to login.

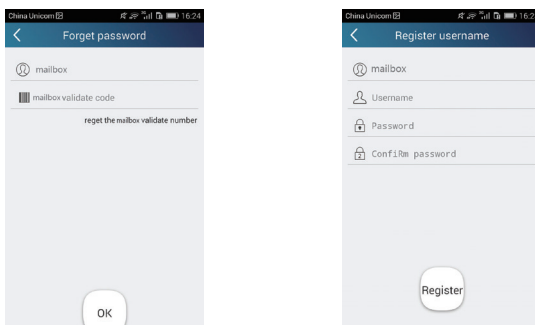

2. Personal setting

Purpose: Set name (device name, preset name, etc.) and image (device image) for the convenience of user identification.

(1) Set device name

After quick configuration, a list of controllable smart devices will be generated.

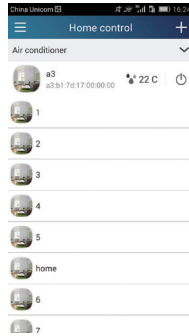

Step 1: Click and hold "a3" to enter the page "Edit device". Click "Image" to select the source of image. Select from "Default images" or "Take a picture" or "Picture gallery" and save an image.

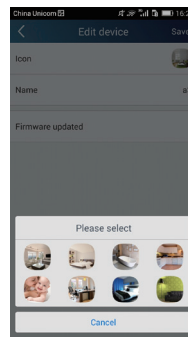
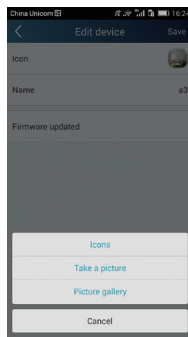

Step 2: Click "Name" to change device name. As shown in the picture, device name is changed to "baby home". Save it and the new device name will be shown.

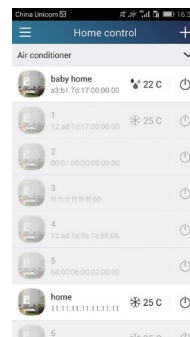
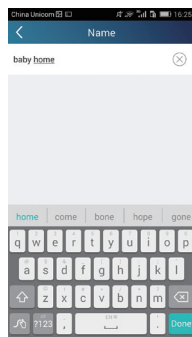

(2) Set preset name

Step 1: Click  at the top right corner of the homepage "Home control". Select "Add preset" and enter the page "Preset edit".

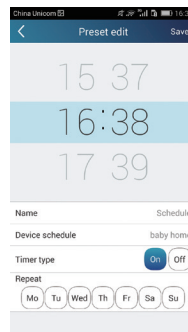

Step 2: Choose the time. Click "Name" to edit it. As shown in the picture, it is edited to "baby room". For timer type, select On. Then select the repeat days. Save the setting of preset name.

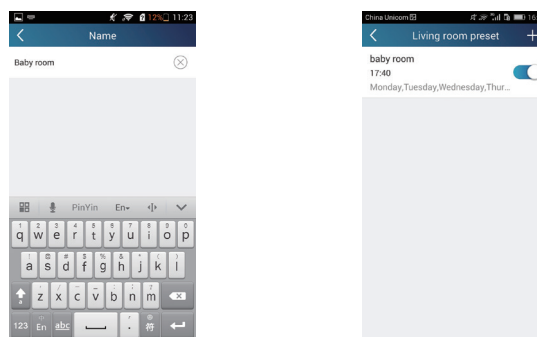

(3) Set device image

Please refer to the steps as instructed in 2(1)

3.Control functions



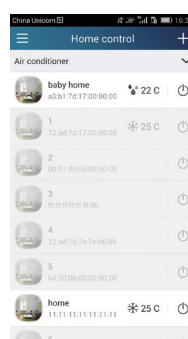

(1) Common control functions: General control on the operation of smart devices(On/Off, temperature, fan speed, mode, etc.) and the setting of advanced functions(Air exchange, dry, heath, light, sleep, energy saving lower limit).

Step 1: General control Enter the homepage "Home control" first. Take "baby home"as an example.

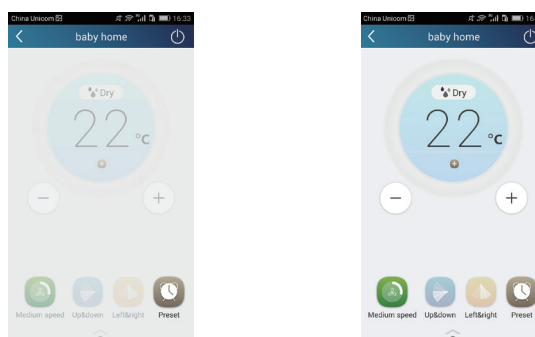



Click "Baby home" and enter the air conditioner control page. Click  to turn on the control switch.

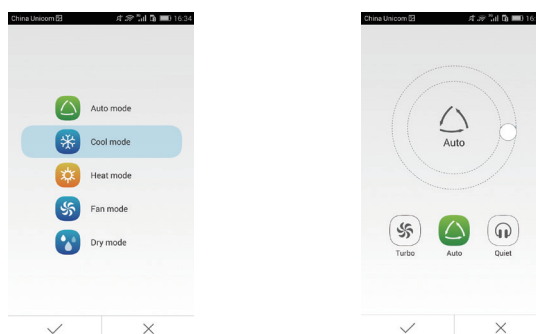

Click  or  to increase or decrease temperature. Click  to adjust working mode. Click  to save the mode. Click  to enter the page of fan speed adjustment.



Click  and go around the circle to select fan speed. Then click  to save the selection.

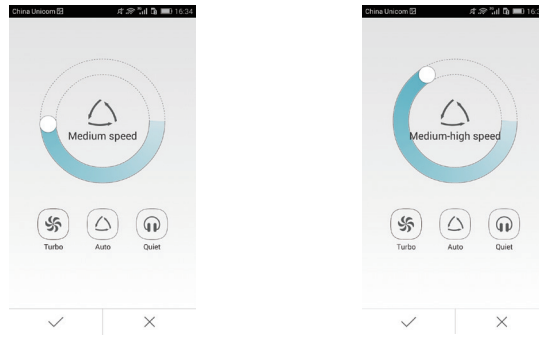

Step 2: Advanced settings Click  to enter advanced settings. You may select "Air", "Dry", "Health", "Light", "Sleep" or "Energy saving/ upper limit".

(2) Advanced control functions: Set scene; Preset; Link; Infrared control (limited to the smart phone with infrared emitter)

Set scene: Preset the operation of several devices by one click On the page "Home control", click the image of "Home control" to enter the page "Edit scene".

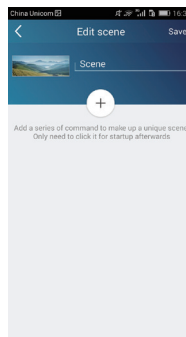

Click "Add scene" and edit the scene name, for example, "back home". Add execution devices.

Click  to add commands. On the page "Select device", select the air conditioner "home". Then select "ON" or "OFF".

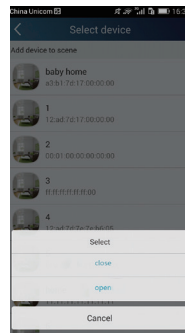
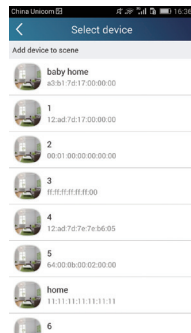

Continue to select the next execution device as instructed above. Click  to set the interval.

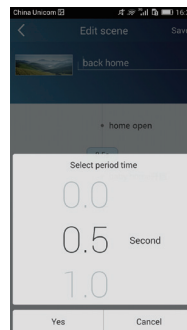
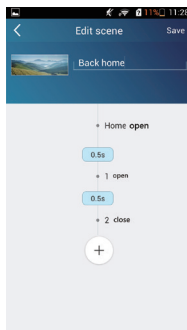

Save it and the scene "back home" will be executed. You may also view the execution condition of the scene.

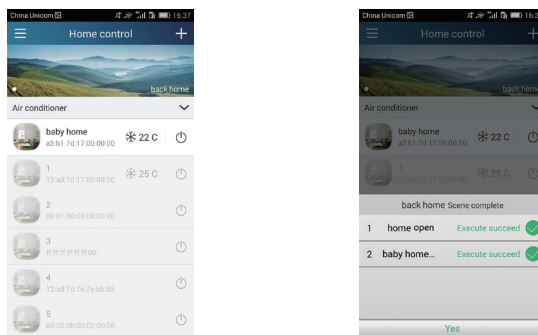

(3) Preset includes single-device preset and multi-device preset Single-device preset: This can preset a certain device to execute On/Off at a specific time.

On the homepage "Home control", take air conditioner "baby home" as an example.

Click the bottom icon  on the page "baby room" to enter the page "Preset edit".

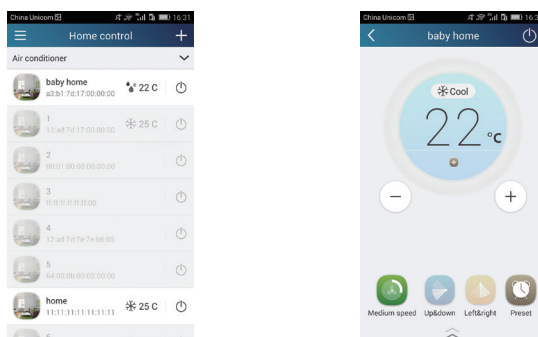

Slide up and down to set the time. If you want to synchronize the time, choose "Synchronize".

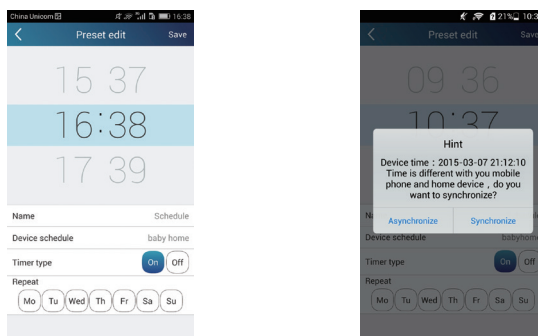

Click "Name" to define the preset name.

Preset device defaults to "baby home". Select "On" as the timer type. Select "Repeat" days to complete the preset.

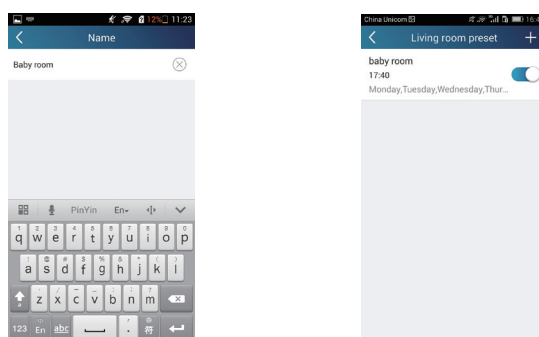

Multi-device preset: This can preset multiple devices to execute at a specified time Please refer to the instructions as how to set preset time, name, timer type and repeat days of a single device.

On the page "Select device", select one or more devices to preset multiple devices. Then return to the page "Home control".

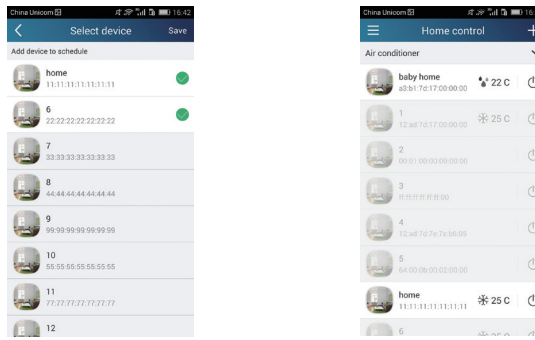

(4) Link(This function is applicable to partial of models)

set in the master device, slave devices will execute commands to realize devices Select a master device. When the environment has satisfied the parameters as linkage.

Step 1: Set the parameters of master device (Select master device, select environment parameters, select master device status).

Click **+** at the top right corner of the homepage "Home control". Select "Link" and enter the page "Add linkage". Select "Device parameter" to enter the page "Select device". Take "baby home" as an example. Select "baby home".

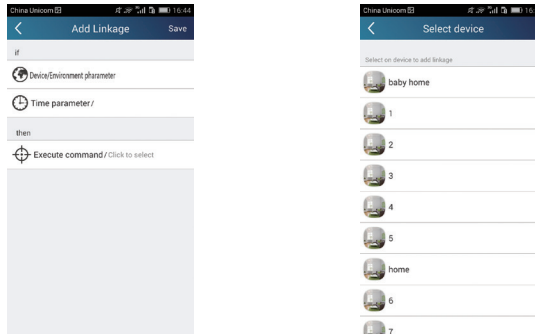

Enter the page "Select environment parameter".

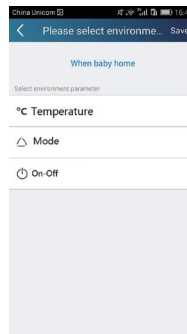

Select "Temperature" to enter the page "Select temp parameter". Slide up and down to adjust temperature. Then select "upper limit" or "lower limit". Click "Mode" and "On-Off" to select the status of master device. Then save the data.

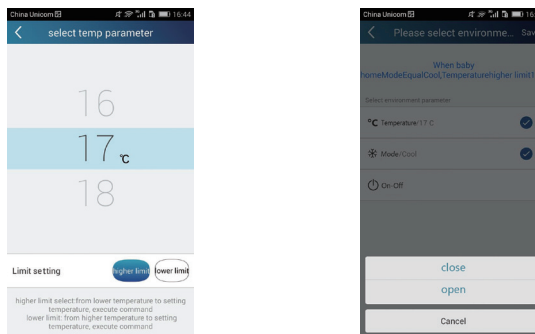

Step 2: Set linkage time parameter. Click "Time parameter" to enter the page "Set time". Slide  right to turn on the setting time.

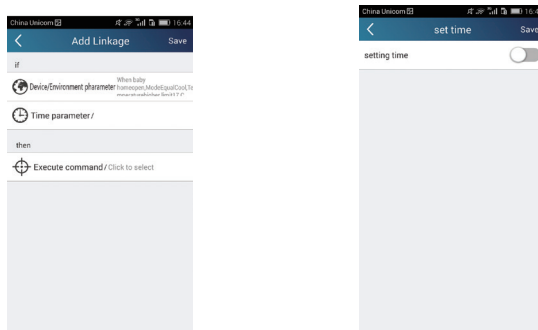

Click "Execution time" to select the start time and stop time. Then click "OK" to save the data.

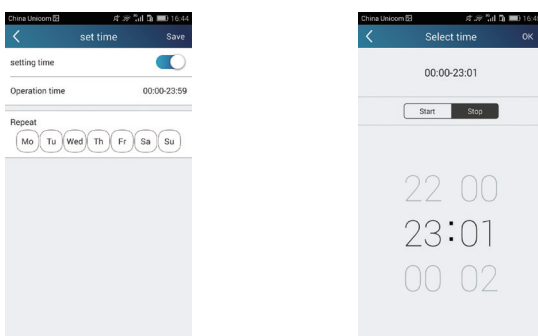

Click the days below "Repeat". Select repeat days and save the data.

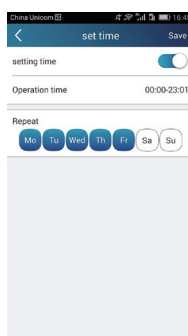

Step 3: Select "Execute command"
 Select "Execute command" and enter the page "Select device".

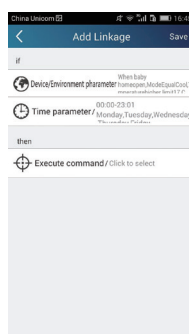

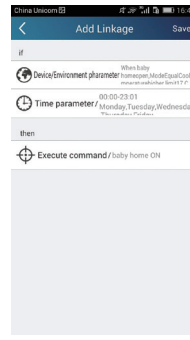
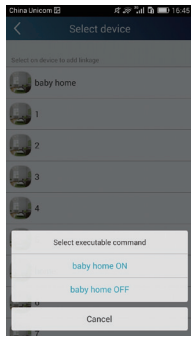

Click the name of device that needs to be controlled. Select "ON" or "OFF" and then save the data to complete the linkage.

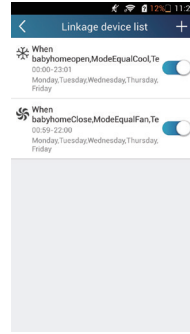
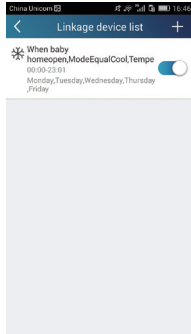

Click "Save". Repeat the above steps to set linkage for several scenes.



(5) Infrared control (limited to the smart phone with infrared emitter)
Function: Smart phone can be used like a remote controller.

Click  at the top right corner of the homepage "Home control". Select "Infrared" and enter the page "Remote controller". Click  and slide up to enter the page of advanced functions.

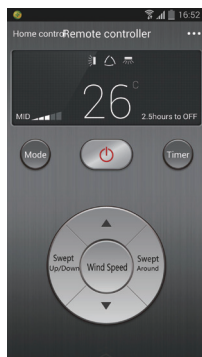

Click  to turn on the device. Click  to select mode. Click  to adjust fan speed, etc. Click "Health", "Energy saving", "Sleep", etc. to set advanced functions.

Click "Sleep" to enter the page "Sleep", on which "Traditional sleep", "Expert sleep", "DIY sleep" can be selected. For example, click "DIY sleep". Then click the left and right arrows to select sleep time and up and down arrows to adjust temperature at a specified sleep time.



4.Menu functions

Menu functions (Share, Set, History, Feedback) functions.

(1) Share: To share quick configuration information and unit's information, including local export and local import. For local import, you just need to select "Local import" and wait for the data download.

Local export

Step 1: Export local data to another smart phone.

Enter "Menu" on the left side and click "Share" to enter the page "Share". Select "Local export".

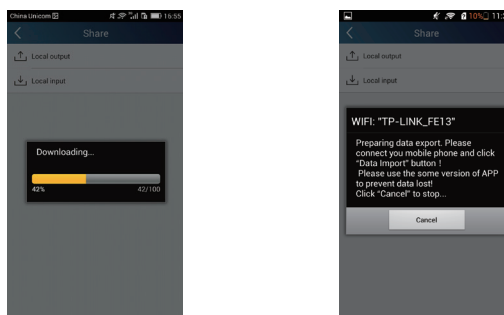

Step 2: Export to another smart phone.

Select the model name and wait for the download.



(2) Backup: To keep backup of the quick configuration information and unit's information, including backup to cloud and backup list on the cloud.

Backup to cloud

Enter "Menu" on the left side and click "Backup".

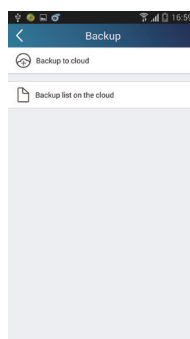

Select "Backup to cloud" and then "Yes". Wait for the data compressing.

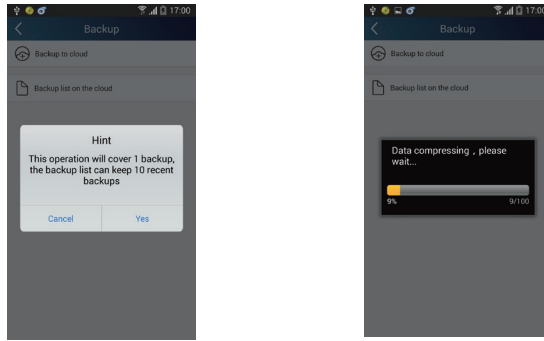

Select "Backup list on the cloud". Then backup records will appear. Click "Record" to download data and recover data to local unit.

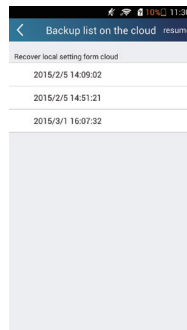

(3) Set
User can set click vibration, message alerts, gesture password (usable only after registration), etc.

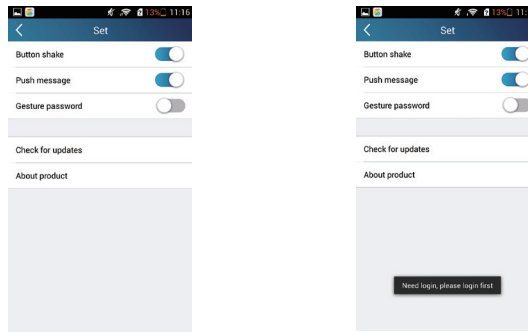

(4) Feedback
User may feedback suggestions to back-stage management for maintenance and development. Click "Feedback". Input your suggestions and submit it.

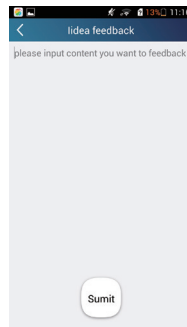

6.3 Operation of Smart Control (Smart Phone, Tablet PC) For Gree

Operation Instructions

Download and install APP

Scan the following QR code (also indicated on package box) with your smart phone and download Wifi Smart.



Install the APP according to its guidance. When successfully installed, your smart phone homepage will show this icon



Configuration

Before operation, please finish the following configuration in order to realize Wifi control and the connection between air conditioner and mobile phone.

1.Short-distance control setting for air conditioner using wifi hotspot

Step 1: Air conditioner wifi is set to AP mode in factory. You can search the air conditioner wifi hotspot through your smart phone. The name of wifi hotspot is the last 8 numbers of the air conditioner mac address. Password is 12345678.

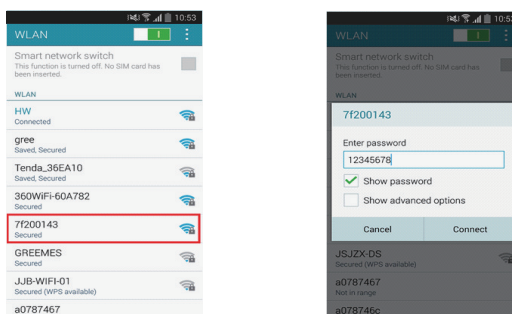

Step 2: Open Gree APP and the screen will show the air conditioner that you just connected. Click this air conditioner to enter and realize short-distance control, as shown below. Please refer to "Functions introduction" for specific control methods.

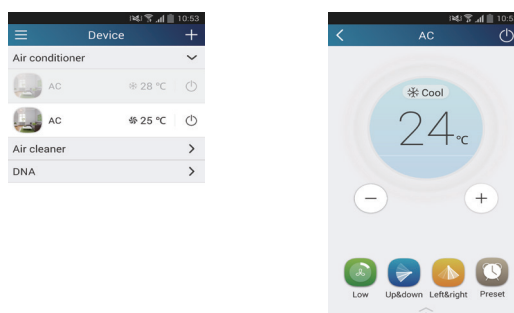

2.Short-distance and long-distance control setting for air conditioner connecting

Step 1: Under short-distance control, return to the homepage "Device". Tap **+** at the top right corner of the homepage "Device". Select "Add device" and enter the page of "Add device". Tap "Manual configuration" and enter the page "Manual configuration".

Step 2: Enter the correct network name and password, select the encrypt mode ""wpa2" and select the server, then tap the button "Add device" for configuration. If configuration succeeds, App will notify user that configuration is successful and return to homepage.

Please note:

Please select the encrypt mode "empty" if your wifi has been set without password.

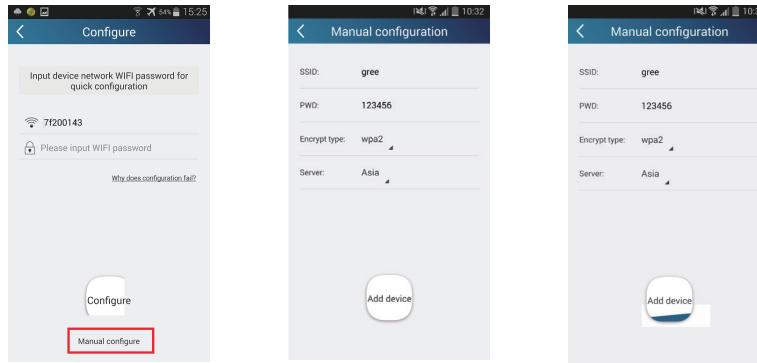

Functions introduction

1. User registration

Purpose: To realize long-distance control

Operation instruction: For the first time login, you have to register a new username. If you already have a username, skip the registration step and enter email address and password on the "Login Page" to log in. If password is forgotten, you can reset the password.

Operation steps:

(1) Account login: Slide the page "Device". and enter the page "Menu" on the left. Tap "Login" to enter the page "Register username". New user must first register a username. Tap "Register".

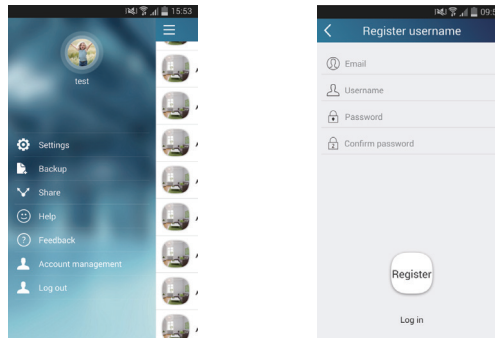

(2) Enter your email address and tap "Get verification code". Wait until you receive the verification code. Enter the code and then tap "OK" to log in. Username will appear. As shown here, the username is "test".

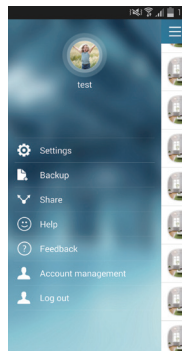

(3) If password is forgotten, you can reset the password with your email address.

Tap "Forgot password" and enter the page "Forgot password". Tap "Verification code" to get a email verification code. Enter a new password and tap "OK" to log in.

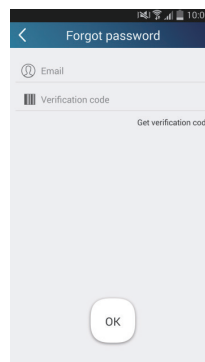

2. Personal setting

Purpose: Set name (device name, preset name, etc.) and images (device image) in order to identify a user easily.

(1) Set device name

After quick configuration, a list of controllable smart devices will be generated. Default name for air conditioner is "AC".

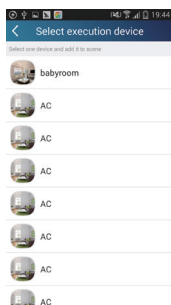

Step 1: Tap and hold "babyroom" to enter the page "Edit device". Tap "Image" to select the source of image. Select from "Default images" or "Take photo" or "Choose from photos" and save an image.

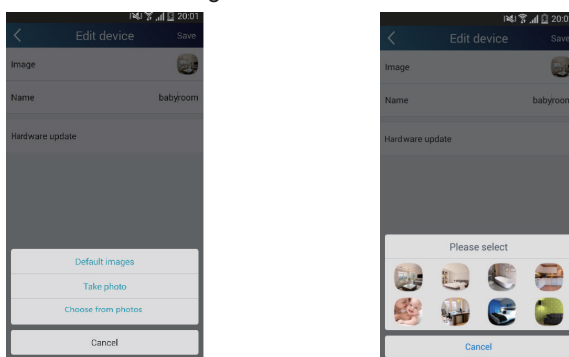

Step 2: Tap "Name" to change device name, enable button "Lock device" to lock the device. Save it and the new device name will be shown.

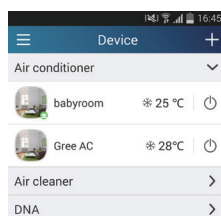

(2) Set preset name

Step 1: Tap  at the top right corner of the homepage "Home control". Select "Add preset" and enter the page "Preset edit".

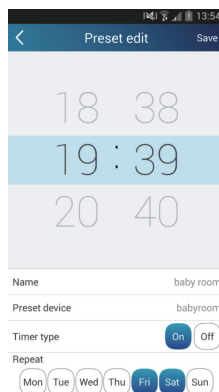

Step 2: Choose the time. Tap "Name". As shown in the picture, its name is "baby room". For timer type, select "On". Then select the repeating days. Save the setting of preset name.

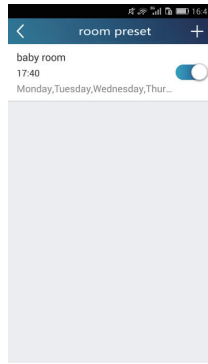

(3) Set device image

Please refer to step 1 in 2(1)

3.Control functions



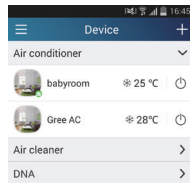

(1) Common control functions: General control on the operation of smart devices (On/Off, temperature, fan speed, mode, etc.) and the setting of advanced functions (air exchange, dry, health, light, sleep, energy saving upper limit).

Step 1: General control Enter the homepage ""Device" first. Take "baby home" as an example.

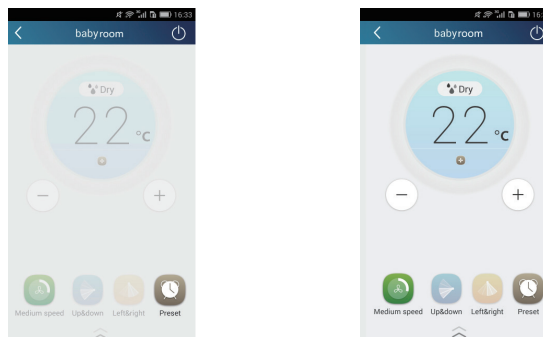

Tap "babyroom" and enter the page of air conditioner control. Tap  to turn on the control switch.



Tap  or  to increase or decrease temperature. Tap  to change working mode. Tap  to enter the page of fan speed adjustment.

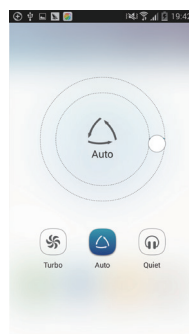

Tap  and go around the circle to adjust fan speed.

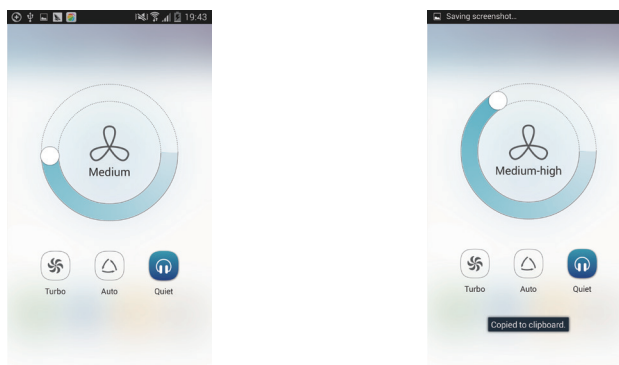

Step 2: Advanced settings Tap  to enter advanced settings. You may select "Air", "Dry", "Health", "Light", "Sleep" or "Energy saving".

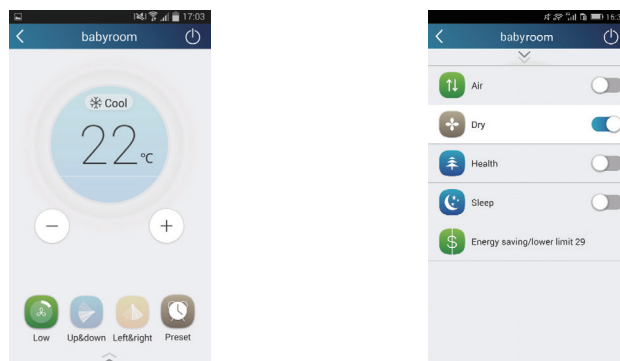

(2) Advanced control functions: Set scene; Preset; Link: Infrared control (only applicable to smart phone with infrared emitter)
 Set scene: Preset the operation of several smart devices by one tap. On the page "Device", tap the image of "Device" to enter the page "Edit scene".

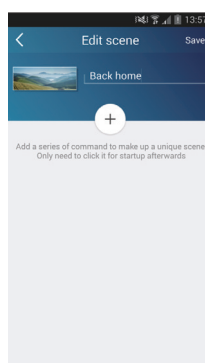

Tap "Add scene" and edit the scene name, for example, "Back home". Add execution devices.
 Tap  to add commands. On the page "Select execution device", select the air conditioner named "babyroom". Then select "ON" or "OFF".

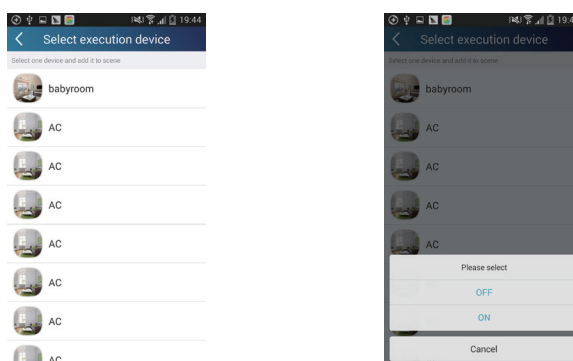

Continue to select the next execution device as instructed above. Tap **0.5s** to set the interval.

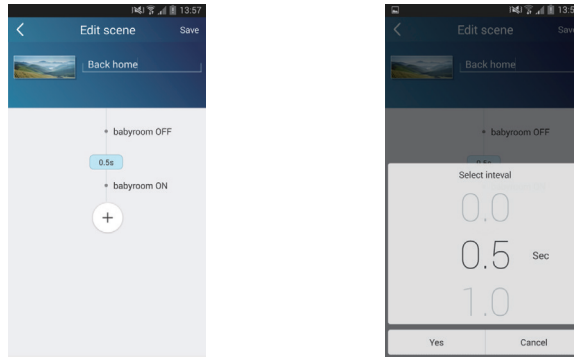

Tap "Save". Tap the scene picture displayed in "Home control" home page to send the command. Then the scene "Back home" will be in execution. You may view the execution condition of the scene.

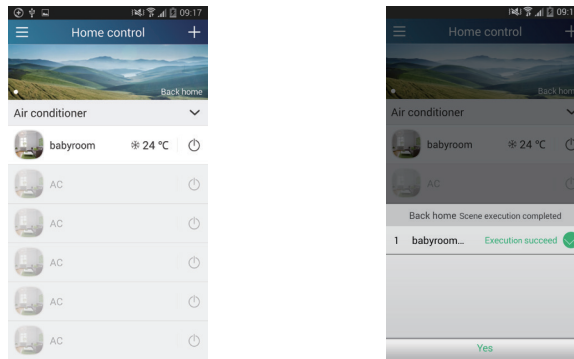

(3) Preset includes single-device preset and multi-device preset Single-device preset: This can preset a certain device to be On/Off at a specific time.

On the homepage "Device", take air conditioner "babyroom" as an example.

Tap  at the bottom of the page "babyroom". Then you will enter the page "Preset edit".

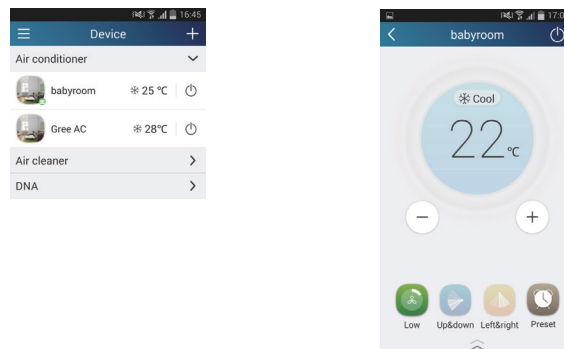

Slide up and down to set the time. If you need to synchronize the time, tap "synchronize".

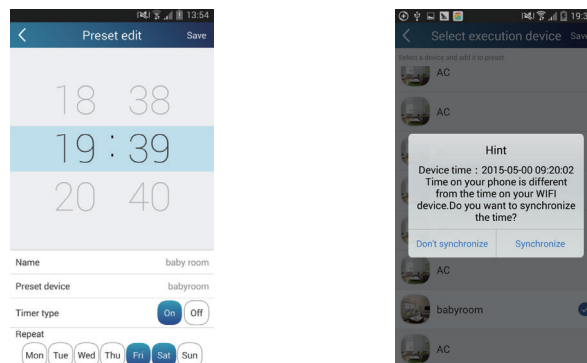

Tap "Name" to customize the preset name.

Preset device can't be selected and it will default to "babyroom". Select "On" for the timer type. Select repeating days to complete the preset.

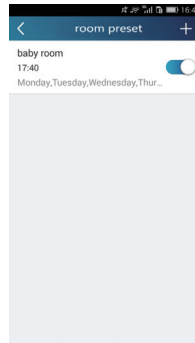

Multi-device preset: This can preset multiple devices to execute a command at a specific time.

Please refer to the instructions as how to set preset time, name, timer type and repeating days for a single device.

Tap "Preset device" to select one or more devices. Then return to the page "Device".

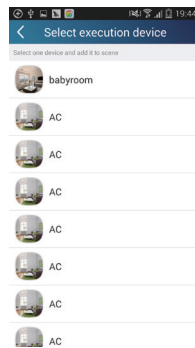

(4) Link(only for the mode with this function)

Select a master device. When the environment has satisfied the parameters as set in the master device, slave devices will execute commands to realize devices linkage.

Step 1: Set the parameters of master device (Select master device, select environment parameters, select master device status).

Tap **+** at the top right corner of the homepage "Device". Select "Link" and enter the page "Add linkage". Tap "Device parameter" to enter the page "Select device". Take "baby room" as an example. Tap "babyroom".

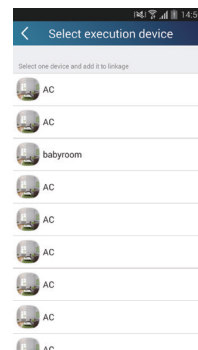
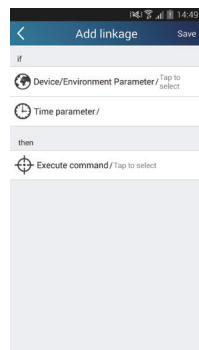

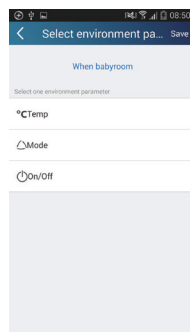

Enter the page "Select environment parameters".

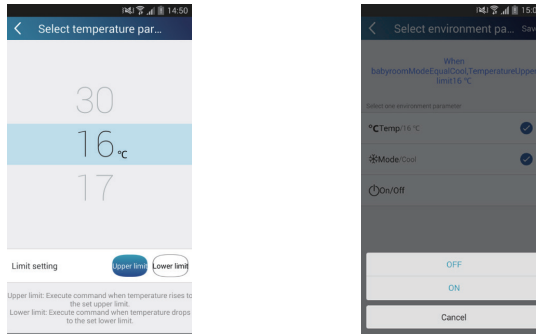

Tap "Temperature" to enter the page "Select temperature parameter". Slide up or down to adjust temperature. Tap "Upper limit" or "Lower limit".

Tap "Mode" and "On/Off" to select the status of master device. Then tap "Save".



Step 2: Set time parameter for linkage. Tap "Time parameter" to enter the page "Set time". Slide  rightwards to turn on the setting time.

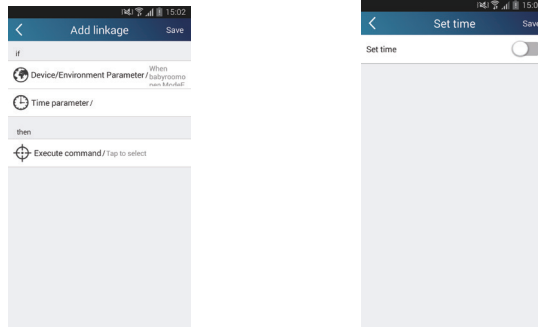

Tap "Execution time"; Then tap "Start" and "Stop" to set start time and stop time respectively. Tap "OK" at the top right corner to save the setting.

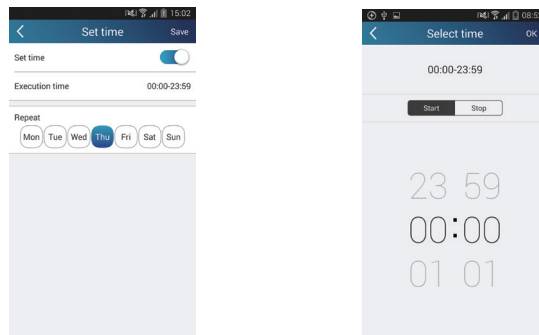

Tap the days below "Repeat" to select the repeating days. Then tap "Save".

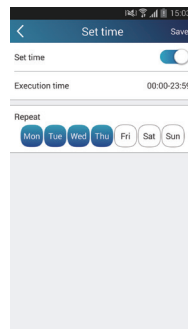

Step 3: Select "Execute command"
Tap "Execute command" and enter the page "Select device".

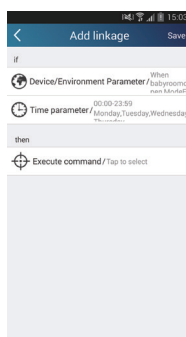

Tap the name of device that you want to control. Tap "ON" or "OFF" and then tap "Save" to complete the linkage.

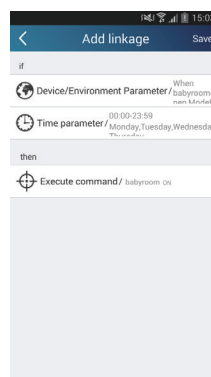
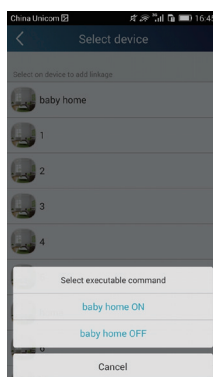

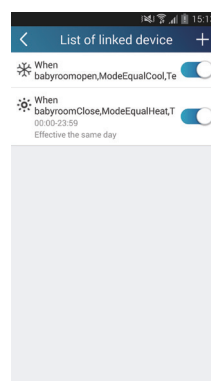
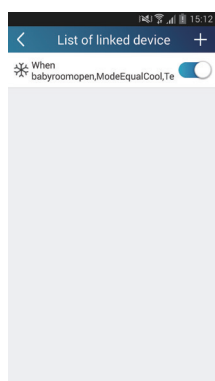

Tap "Save" and then repeat the above steps to set linkage of several scenes.



(5) Infrared control (only applicable to smart phone with infrared emitter).

Function: Smart phone can be used as a remote controller.

Tap  at the top right corner of the homepage "Home control". Select "Infrared" and enter the page "Remote controller".  Tap and slide up to enter the page of advanced functions.

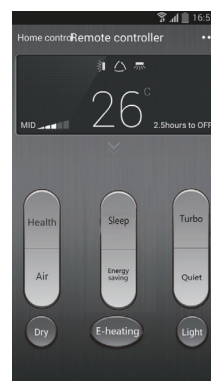

Tap  to turn on the device. Tap  to select mode. Tap  to adjust fan speed . Tap "Health", "Energy saving", "Sleep" etc. to set advanced functions.

Tap "Sleep" to enter the page "Sleep". You can select "Traditional sleep", "Expert sleep" or "DIY sleep". Tap "DIY sleep" and then tap the left and right arrows to set sleep time. Tap up and down arrows to adjust temperature at a specific sleep time.

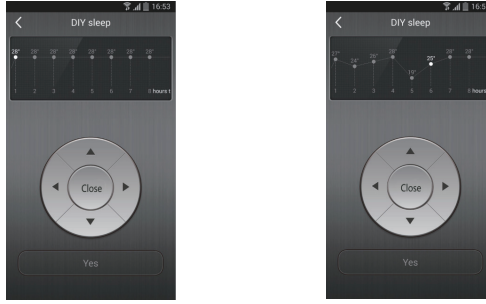

4. Menu functions

Menu functions (Share, Set, History, Feedback)

(1) Share: To share quick configuration information and unit's information, including local export and local import. For local import, you just need to tap "Local import" and wait for the data download.

Local export

Step 1: Export local data to another smart phone.

Enter "Menu" on the left side and tap "Share" to enter the page "Share". Then tap "Local export".

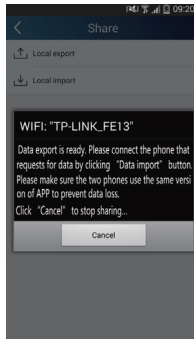

Step 2: Another smart phone to be imported.

Tap the model name and wait for the download.

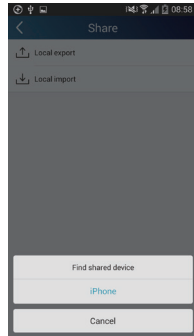

(2) Backup: To keep backup of the quick configuration information and unit's information, including backup to cloud and backup list on the cloud.

Backup to cloud

Enter the "Menu" on the left and tap "Backup".

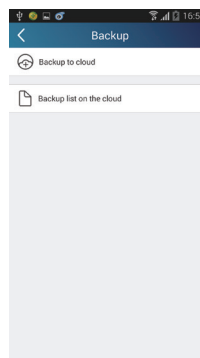

Tap "Backup to cloud" and then tap "Yes". Then wait for the data download.

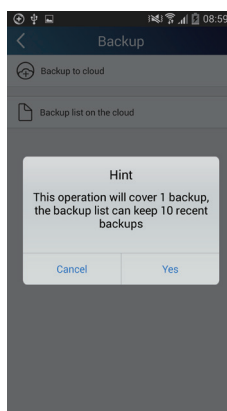

Select "Backup list on the cloud". Then backup records will appear. Tap "Record" to download data and recover data to local unit.

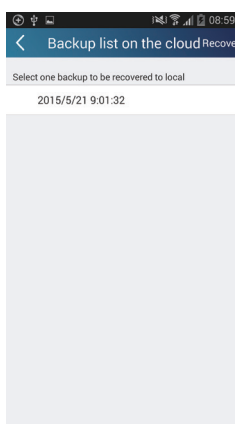

(3) Settings

User can set vibration, message alerts, gesture password (usable only after registration), etc.

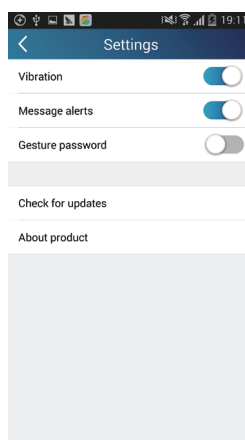

(4) Feedback

User can feedback suggestions to back-stage management for maintenance and development.

Tap "Feedback". Enter your suggestions and then submit it.

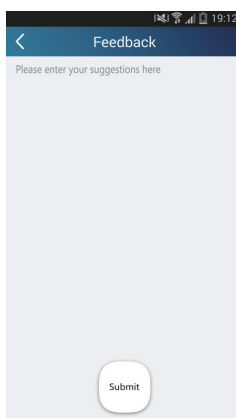

6.4 Brief Description of Modes and Functions

1. Cooling mode

- (1) Under this mode, the fan and the up swing will operate at setting status. The temperature setting range is 16~30°C.
- (2) The unit is stopped because of malfunction of outdoor unit or protection. The indoor unit keeps original operation status and the error code is displayed.
- (3) Indoor unit is stopped due to mode shock.

2. Drying mode

- (1) Under this mode, the fan operates at low speed and the swing operates at setting status. The temperature setting range is 16~30°C.
- (2) The unit is stopped because of malfunction of outdoor unit or protection. The indoor unit keeps original operation status and the error code is displayed.

3. Heating mode

- (1) Under this mode, the temperature setting range is 16~30°C.
- (2) Working condition and process for heating
When the unit is turned on under heating mode, the indoor unit turns to cold air prevention status. When the unit is turned off and the indoor unit has been started up before, the indoor unit blows the residual heat.
- (3) Protection function: When the compressor is stopped due to malfunction under heating mode, the indoor unit blows the residual heat.
- (4) Blow residual heat
When the unit stops operation as it reaches the temperature point, indoor unit will continue to run for 60s. The fan speed cant be switched during blowing residual heat period. The upper horizontal louver will turn to the defaulted position in cooling. When the unit operates under heating mode or auto heating mode, compressor will be turned on and the corresponding electric expansion valve is more than 65 and the unit stops operation during the operation status of indoor unit. The upper horizontal louver will turn to the defaulted position in heating mode. The indoor unit operates at low speed for 10s and then the unit stops operation.
- (5) Defrosting, oil-returning
As it received the signal of defrosting and oil-returning from outdoor unit, the upper horizontal louver will turn to the minimum angle in cooling. 10s later, the in door fan stop operation. During defrosting and oil-returning process and they are quitted within 5mins, all malfunctions for indoor tube temperature sensor wont be detected.

4. Working process for AUTO mode (Mode judgment will be performed every 30s)

Under AUTO mode, standard cooling Tpreset=25°C (77°F), standard heating Tpreset=20°C (68°F), and standard fan Tpreset= 25°C (77°F).

- (1) When Tamb≥26°C (79°F), the unit operation in cooling mode;
- (2) Heating pump unit: When Tamb≤19°C (66°F), the unit operates in heating mode;
- (3) Cooling only unit: Tamb≤19°C (66°F), the unit operates in fanmode;
- (4) When 19°C<Tindoor amb.<26°C, if it turns to auto mode as the unit is turned on for the first time the unit will operates at auto fan mode. If it switch to auto mode from other modes, the unit will keep previous operation mode (when it turns to dry mode, the unit operates at auto fan mode).
- (5) Protection function
Protection function is the same as that in cooling or heating mode.

5. Fan mode

Under fan mode, only indoor fan and swing operates. When it operates at auto fan speed, it will operate according to auto fan speed condition in cooling.

6. Mode shock

If the mode shock is 1 which is received by indoor unit from outdoor unit, the loads of indoor unit (indoor unit, auxiliary heating,swing) stop operation and the error code is displayed. The mode sent to outdoor unit is still remote control receiving mode. The unit will be turned off during mode shock.

If timer ON is reached, and the mode shock is 1 which is received by indoor unit from outdoor unit, the loads of indoor unit (indoor unit,auxiliary heating, swing) stop operation and the error code is displayed. The mode sent to outdoor unit is still remote control receiving mode.

7. Other control

7.1 Buzzer

Upon energization or availably operating the unit or remote controller, the buzzer will give out a beep.

7.2 Auto button

If this button is pressed, the unit will operate in AUTO mode and indoor fan will operate at auto speed; meanwhile, the swing motor operates. Press this button again to turn off the unit.

7.3 8 °C heating function

Under heating mode, press TEMP+CLOCK buttons simultaneously. Under this mode, "cold air prevention protection" will be shielded.

7.4 I FEEL function

When I FEEL command is received, the controller will operate according to the ambient temperature sent by the remote controller (For defrosting and cold blow prevention, the unit operates according to the ambient temperature sensed by the air conditioner). The remote controller will send ambient temperature data to the controller every 10min. When the data has not been received after 11mins, the unit will operate according to the temperature sensed by the air conditioner. If I FEEL function is not selected, the ambient temperature will be that sensed by the air conditioner. I FEEL function will not be memorized.

7.5 Timer function

General timer and clock timer functions are compatible by equipping remote controller with different functions.

(1) General Timer

Timer ON can be set at unit OFF. If selected ON time is reached, the unit will start to operate according to previous setting status. Time setting range is 0.5-24hr in 30-minute increments.

Timer OFF can be set at unit ON. If selected OFF time is reached, the unit will stop operation. Time setting range is 0.5-24hr in 30-minute increments.

(2) Clock Timer

Timer ON

If timer ON is set during operation of the unit, the unit will continue to operate. If timer ON is set at unit OFF, upon ON time reaches the unit will start to operate according to previous setting status.

Timer OFF

If timer OFF is set at unit OFF, the system will keep standby status. If timer OFF is set at unit ON, upon OFF time reaches the unit will stop operation.

Timer Change

Although timer has been set, the unit still can be turned on/off by pressing ON/OFF button of remote controller. You can also set the timer once again, and then the unit will operate according to the last setting. If timer ON and timer OFF are set at the same time during operation of the unit, the unit will keep operating at current status till OFF time reaches. If timer ON and timer OFF are set at the same time at unit OFF, the unit will keep stop till ON time reaches. In the future's every day, the system will operate according to presetting mode till OFF.

7.6 Sleep function

This mode is only valid in cooling and heating modes. The unit will select proper sleep curve to operate according to different set temperature.

7.7 Compulsory defrosting function

When the unit is turned on in heating by remote controller and the set temperature is 16°C, press "+,-,+,-,+,-" continuously within 5s, the indoor unit turns to compulsory defrosting setting and it will send compulsory defrosting mode to outdoor unit.

When indoor unit received the compulsory defrosting signal from outdoor unit, the indoor unit will quit from the compulsory defrosting setting and it will cancel to send compulsory defrosting mode to outdoor unit.

7.8 Refrigerant recovery function

Turn to Freon recovery mode: After the unit is energized for 5min, and the unit is turned on at 16°C under cooling mode, press light button on remote controller for 3 times successively within 3s to turn to Freon recovery mode. Fo is displayed and it will send Freon recovery mode to outdoor unit.

Quit from Freon recovery mode: After it turns to Freon mode, if it receives any signal from remote controller or it turns to Freon recovery mode for 25 mins, it will quit from Freon recovery mode.

Turn to the action for Freon recovery mode: indoor unit will be turned on in cooling mode. The fan speed is super-high fan speed and the set temperature is 16°C. The horizontal louver will turn to the minimum operation angle.

Quit the action for Freon recovery mode: The indoor fan operates at the previous set status by remote controller.

7.9 Pilot run function

When the set temperature is 30°C under cooling mode, press "+,-,+,-,+,-" continuously within 5s, the indoor unit turns to pilot run setting mode and it will send pilot run mode to outdoor unit.

Pilot run mode: it operates under cooling mode and "dd" is displayed.

Quit the pilot run mode and indoor unit cancels "dd" display. If it receives "wrong wire connection of malfunction of expansion valve" from outdoor unit, "dn" will be displayed.

Part II : Installation and Maintenance

7. Notes for Installation and Maintenance

Safety Precautions: Important!

Please read the safety precautions carefully before installation and maintenance.

The following contents are very important for installation and maintenance.

Please follow the instructions below.

- The installation or maintenance must accord with the instructions.
- Comply with all national electrical codes and local electrical codes.
- Pay attention to the warnings and cautions in this manual.
- All installation and maintenance shall be performed by distributor or qualified person.
- All electric work must be performed by a licensed technician according to local regulations and the instructions given in this manual.
- Be caution during installation and maintenance. Prohibit incorrect operation to prevent electric shock, casualty and other accidents.



Warnings

Electrical Safety Precautions:

1. Cut off the power supply of air conditioner before checking and maintenance.
2. The air condition must apply specialized circuit and prohibit share the same circuit with other appliances.
3. The air conditioner should be installed in suitable location and ensure the power plug is touchable.
4. Make sure each wiring terminal is connected firmly during installation and maintenance.
5. Have the unit adequately grounded. The grounding wire can't be used for other purposes.
6. Must apply protective accessories such as protective boards, cable-cross loop and wire clip.
7. The live wire, neutral wire and grounding wire of power supply must be corresponding to the live wire, neutral wire and grounding wire of the air conditioner.
8. The power cord and power connection wires can't be pressed by hard objects.
9. If power cord or connection wire is broken, it must be replaced by a qualified person.

10. If the power cord or connection wire is not long enough, please get the specialized power cord or connection wire from the manufacture or distributor. Prohibit prolong the wire by yourself.

11. For the air conditioner without plug, an air switch must be installed in the circuit. The air switch should be all-pole parting and the contact parting distance should be more than 3mm.

12. Make sure all wires and pipes are connected properly and the valves are opened before energizing.

13. Check if there is electric leakage on the unit body. If yes, please eliminate the electric leakage.

14. Replace the fuse with a new one of the same specification if it is burnt down; don't replace it with a cooper wire or conducting wire.

15. If the unit is to be installed in a humid place, the circuit breaker must be installed.

Installation Safety Precautions:

1. Select the installation location according to the requirement of this manual.(See the requirements in installation part)
2. Handle unit transportation with care; the unit should not be carried by only one person if it is more than 20kg.
3. When installing the indoor unit and outdoor unit, a sufficient fixing bolt must be installed; make sure the installation support is firm.
4. Wear safety belt if the height of working is above 2m.
5. Use equipped components or appointed components during installation.
6. Make sure no foreign objects are left in the unit after finishing installation.

Refrigerant Safety Precautions:

1. Avoid contact between refrigerant and fire as it generates poisonous gas; Prohibit prolong the connection pipe by welding.
2. Apply specified refrigerant only. Never have it mixed with any other refrigerant. Never have air remain in the refrigerant line as it may lead to rupture or other hazards.
3. Make sure no refrigerant gas is leaking out when installation is completed.
4. If there is refrigerant leakage, please take sufficient measure to minimize the density of refrigerant.
5. Never touch the refrigerant piping or compressor without wearing glove to avoid scald or frostbite.

Improper installation may lead to fire hazard, explosion, electric shock or injury.

Main Tools for Installation and Maintenance

| | | |
|--|---|--|
| <p>1. Level meter, measuring tape</p>  | <p>2. Screw driver</p>  | <p>3. Impact drill, drill head, electric drill</p>  |
| <p>4. Electroprobe</p>  | <p>5. Universal meter</p>  | <p>6. Torque wrench, open-end wrench, inner hexagon spanner</p>  |
| <p>7. Electronic leakage detector</p>  | <p>8. Vacuum pump</p>  | <p>9. Pressure meter</p>  |
| <p>10. Pipe pliers, pipe cutter</p>  | <p>11. Pipe expander, pipe bender</p>  | <p>12. Soldering appliance, refrigerant container</p>  |

8. Installation

8.1 Requirements for Electric Connection

1. Safety Precaution

- (1) Must follow the electric safety regulations when installing the unit.
- (2) If the supply cord is damaged, it must be replaced by the manufacturer or its service agent or a similarly qualified person in order to (avoid a hazard).
- (3) According to the local safety regulations, use qualified power supply circuit and air switch.
- (4) A air switch having a contact separation of at least 3mm in all poles should be fixed in fixed wiring.
- (5) The appliance shall be installed in accordance with national wiring regulation.
- (6) The air switch must have the functions of magnetic tripping and heat tripping in order to prevent short circuit or overload. Please install the air switch with suitable capacity according to the sheet below.
- (7) Make sure the power supply matches with the requirement of air conditioner. Unstable power supply or incorrect wiring may result in electric shock, fire hazard or malfunction. Please install proper power supply cables before using the air conditioner.
- (8) Properly connect the live wire, neutral wire and grounding wire of power socket.
- (9) Be sure to cut off the power supply before proceeding any work related to electric safety.
- (10) Do not put through the power before finishing installation.

2. Grounding Requirement

- (1) The air conditioner is first class electric appliance. It must be properly grounded with specialized grounding device by a professional. Please make sure it is always grounded effectively, otherwise it may cause electric shock.
- (2) The yellow-green wire in air conditioner is grounding wire, which can't be used for other purposes.
- (3) The grounding resistance should comply with national electric safety regulations.

| Air-Conditioner | Air Switch Capacity |
|-----------------|---------------------|
| 12、18K | 16A |

8.2 Installation of indoor unit

1. Selection of Installation Location

- (1) Such a place where cool air can be distributed throughout the room.
- (2) Such a place where condensation water is easily drained out.
- (3) Such a place that can handle the weight of indoor unit.
- (4) Such a place which has easy access for maintenance.
- (5) The appliance shall not be installed in the laundry.

There are 2 styles of installation

- Ceiling type
- Floor type

Each type is similar to the other as follows:

The indoor unit should be sited in a place where:

- (1) The restrictions on installation specified in the indoor unit installation drawings are met.
- (2) Both air intake and exhaust have clear paths met.
- (3) The unit is not in the path of direct sunlight.
- (4) The unit is away from the source of heat or steam.
- (5) There is no source of machine oil vapour (this may shorten indoor unit life).
- (6) Cool(warm) air is circulated throughout the room.
- (7) The unit is away from electronic ignition type fluorwscent lamps (inverter or rapid stert type) as they may shorten the remote controller range.
- (8) The unit is at least 1 metre away from any television or radio set(unit may cause interference with the picture or sound).

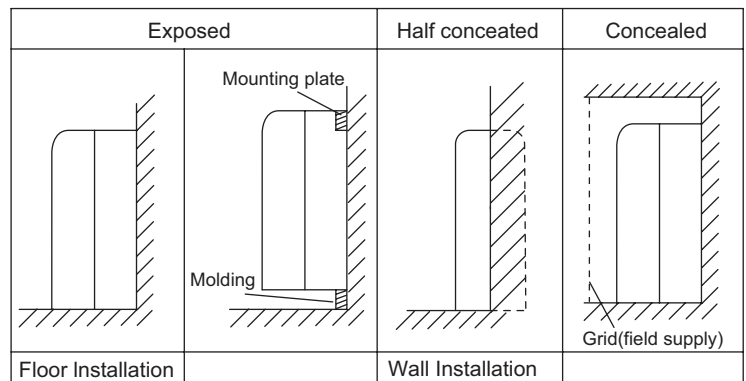

Location for securing the installation panel.

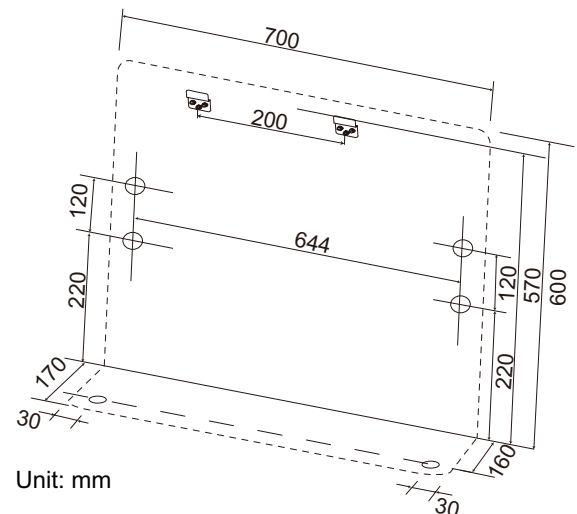

Cautions for installation where air conditioner troubles liable to occur.

- Where there is too much of oil area.
- Where it is acid base area.
- Where there is irregular electrical supply.

2. Indoor Unit Installation Drawings

The indoor unit may be mounted in any of the three styles shown here.

Console unit shall be installed on the ground or the position where is 0.3m from the floor.

Schematic drawing of hooks:

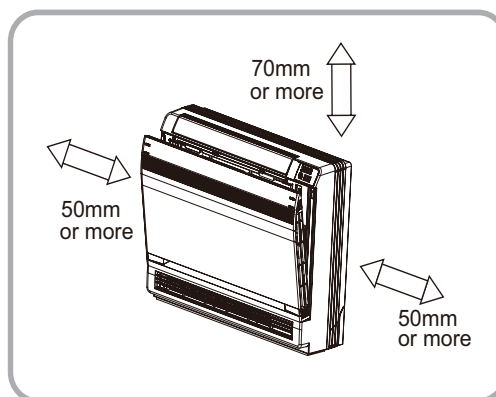
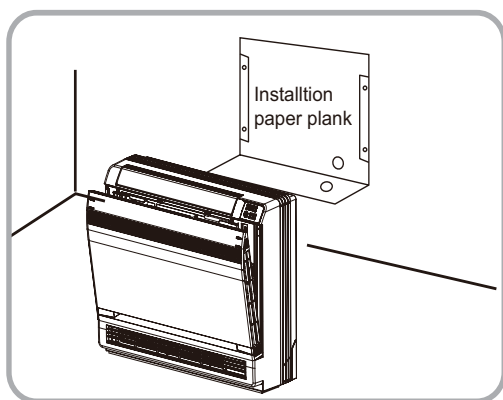
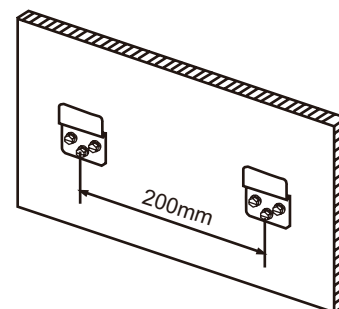

3. Refrigerant Piping

- (1) Drill a hole (65mm in diameter) in the spot indicated by the symbol in the illustration ad below .
- (2) The location of the hole is different depending on which side of the pipe is taken out .
- (3) For piping ,see6.Connecting the refrigerant pipe , under Indoor Unit Installation.
- (4) Allow space around the pipe for a easier indoor unit pipe connection.

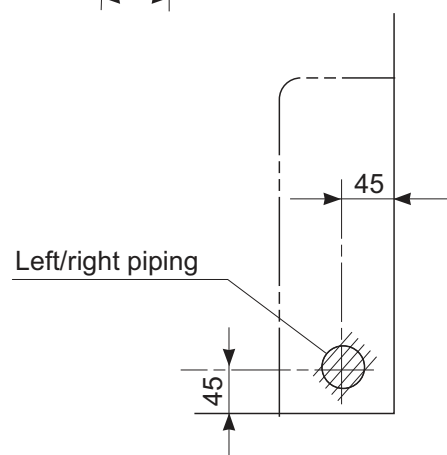
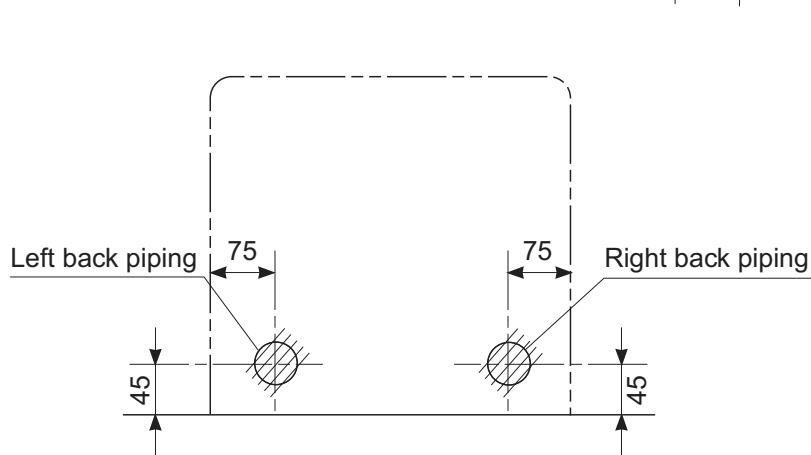
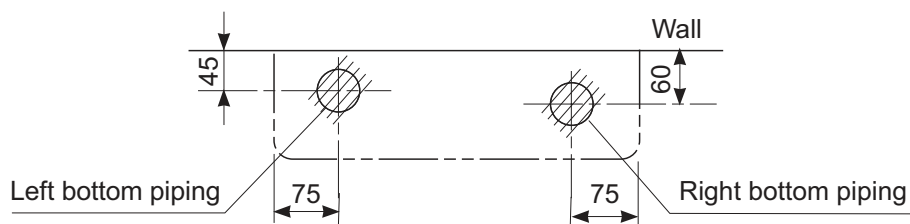

Unit: mm

CAUTION

Min.allowable length

- The suggested shortest pipe length is 2.5m,in order to avoid noise from the outdoor unit and vibration. (Mechanical noise and vibration may occur depending on how the unit is installed and the environment in which it is used.)
- See the installation manual for the outdoor unit for the maximum pipe length.
- For multi-connections ,see the installation manual for the multi-outdoor unit.

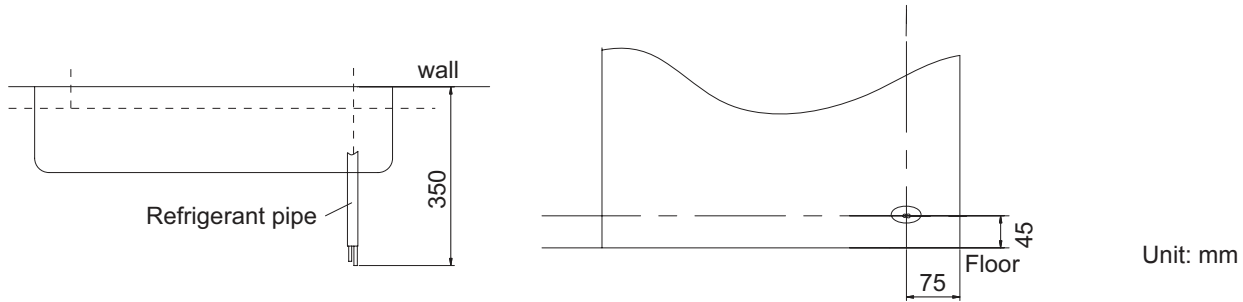

4. Boring a Wall Hole and Installing Wall Embedded Pipe

- For walls containing metal frame or metal board ,be sure to use a wall embedded pipe and wall cover in the feed-through hole to
- Be sure to caulk the gaps around the pipes with caulking material to prevent water leakage.

- (1) Bore a feed-through hole of 55mm in the wall so it has a down slope toward the outside.
- (2) Insert a wall pipe into the hole.
- (3) Insert a wall cover into wall pipe .
- (4) After completing refrigerant piping, wiring, and drain piping, caulk pipe hole gap with putty.

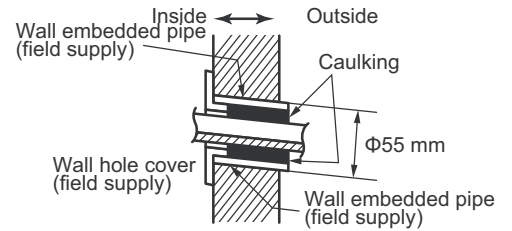

5. Drain Piping

- (1) Use commercial rigid polyvinyl chloride pipe general VP 20 pipe, outer diameter 26mm, inner diameter 20mm for the drain pipe.
- (2)The drain hose (outer diameter 18mm at connecting end, 2200mm long)is supplied with the indoor unit. Prepare the drain pipe picture below position.
- (3) The drain pipe should be inclined downward so that water will flow smoothly without any accumulation.(Should not be trap.)
- (4) Insert the drain hose to this depth so it wont be pulled out of the drain pipe.
- (5) Insulate the indoor drain pipe with 10mm or more of insulation material to prevent condensation.
- (6) Remove the air filters and pour some water into the drain pan to check the water flows smoothly.

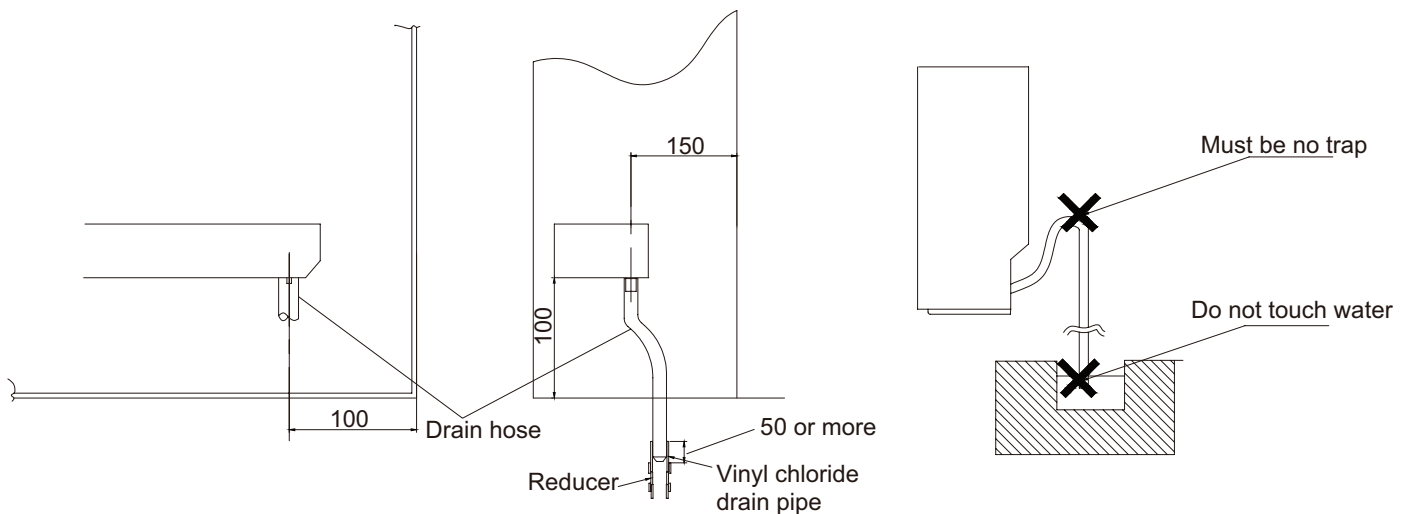

Unit: mm

6. Installing Indoor Unit

Preparation

- Open the front panel, remove the 4 screws and dismount the front grille while pulling it forward.
- Follow the arrows to disengage the clasps on the front case to remove it.
- Follow the procedure below when removing the slit portions.

■ For Moldings

- Remove the pillars. (Remove the slit portions on the bottom frame using nippers.)

■ For Side Piping

- Remove the pillars.
- (1) Remove the 7 screws.
 - (2) Remove the upper casing (2 tabs).
 - (3) Remove the left and right casings (2 tabs on each side).
 - (4) Remove the slit portions on the bottom frame and casings using nippers.
 - (5) Return by following the steps in reverse order (3>2>1).

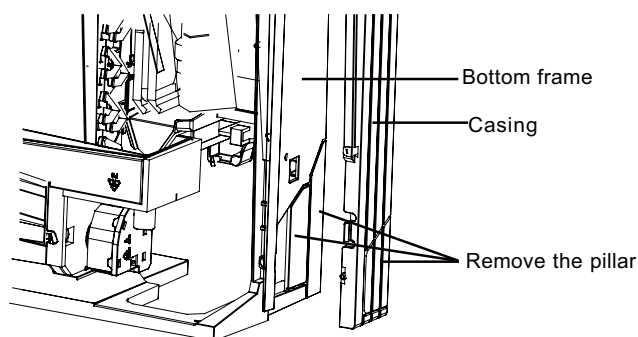
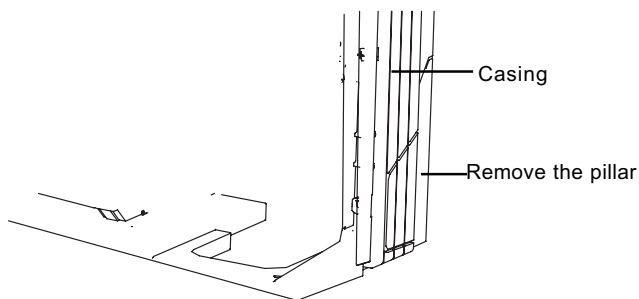
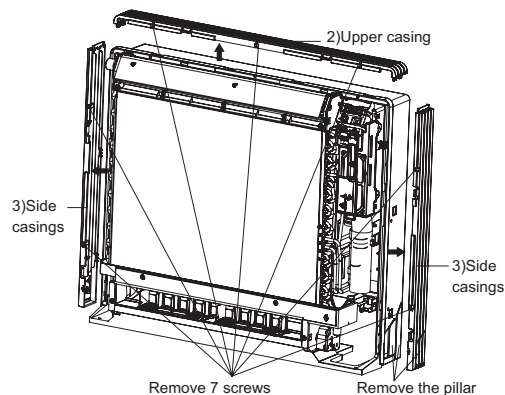
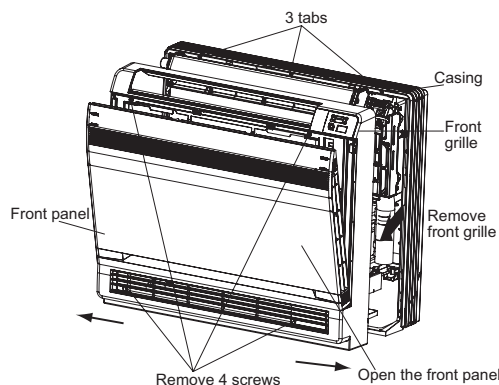

Installation

- Secure using 6 screws for floor installations. (Do not forget to secure to the rear wall.)
 - For wall installations, secure the mounting plate using 5 screws and the indoor unit using 4 screws. The mounting plate should be installed on a wall which can support the weight of the indoor unit.
- (1) Temporarily secure the mounting plate to the wall, make sure that the panel is completely level, and mark the boring points on the wall.
 - (2) Secure the mounting plate to the wall with screws.

Floor Installation

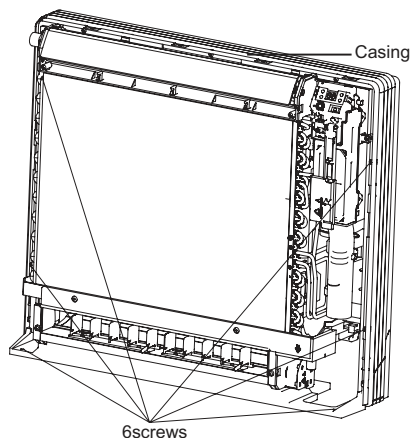

Wall Installation

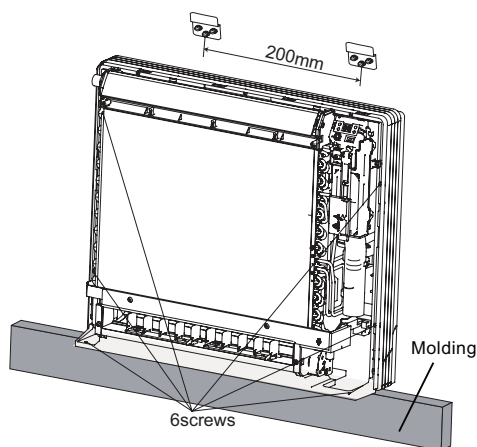

- (3) Once refrigerant piping and drain piping connections are complete, fill in the gap of the through hole with putty. A gap can lead to condensation on the refrigerant pipe, and drain pipe, and the entry of insects into the pipes.
- (4) Attach the front panel and front grille in their original positions once all connections are complete.

7. Flaring the Pipe End

- (1) Cut the pipe end with a pipe cutter.
- (2) Remove burrs with the cut surface facing downward so that the chips do not enter the pipe.
- (3) Fit the flare nut on the pipe.
- (4) Flare the pipe.
- (5) Check that the flaring is properly made.

⚠ CAUTION

- (1) **DO not use mineral oil on flared part.**
- (2) **Prevent mineral oil from getting into the system as this would reduce the lifetime of the units.**
- (3) **Never use piping which had been used for previous installations. Only use parts which are delivered with the unit.**
- (4) **Do never install a drier to this R410A unit in order to guarantee its lifetime.**
- (5) **The drying material may dissolve and damage the system.**
- (6) **Incomplete flaring may cause refrigerant gas leakage.**

Cut exactly at right angles

Remove burrs

Flaring

Set exactly at the position shown below

| Flare tool for R410A | Conventional flare tool | |
|----------------------|-------------------------|-------------------------------|
| | Clutch-type | Wing-nut type (Imperial-type) |
| A | 0-0.5mm | 1.5-2.0mm |

Flare's inner surface must be scratch-free

The pipe end must be evenly flared in a perfect circle

Make sure that the flare nut is fitted

8. Connecting the Refrigerant Pipe

- (1) Use torque wrenches when tightening the flare nuts to prevent damage to the flare nuts and gas leaks.

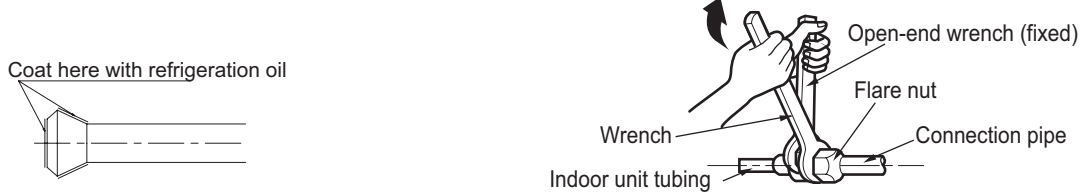

- (2) Align the centres of both flares and tighten the flares and tighten the flare nuts 3 or 4 turns by hand. Then tighten them fully with the torque wrenches.
- (3) To prevent gas leakage, apply refrigeration oil on both inner and outer surfaces in the flare. (Use refrigeration oil for R410A.)

| Flare nut tightening torque | | |
|-----------------------------|-----------|-------------|
| Gas side | | Liquid side |
| 12K | 18K | 12K/18K |
| 3/8 inch | 1/2 inch | 1/4 inch |
| 31-35 N.m | 50-55 N.m | 15-20 N.m |

Caution on Piping Handling

- (1) Protect the open end of the pipe against dust and moisture.
- (2) All pipe bends should be as gentle as possible. Use a pipe bender for bending. (Bending radius should be 30 to 40mm or larger.)

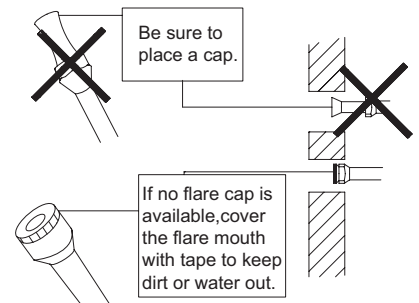

Selection of Copper and Heat Insulation Materials

When using commercial copper pipes and fittings, observe the following:

- (1) Insulation material: Polyethylene foam
Heat transfer rate: 0.041 to 0.052W/mK (0.035 to 0.045kca/(mh°C)
Refrigerant gas pipes surface temperature reaches 110 max.
Choose heat insulation materials that will withstand this temperature.

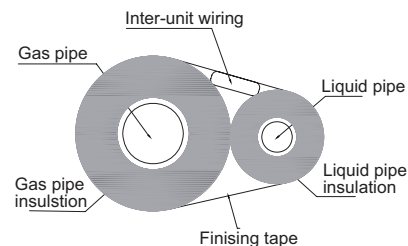

- (2) Be sure to insulate both the gas and liquid piping and to provide insulation dimensions as below.

| Gas side | | Liquid side | Gas pipe thermal insulation | | Liquid pipe thermal insulation |
|-----------------|-------------|-------------|-----------------------------|--------------|--------------------------------|
| 12K | 18K | | 12K | 18K | |
| O.D. 9.55mm | O.D. 12.7mm | O.D. 6.4mm | I.D. 12-15mm | I.D. 14-16mm | I.D. 8-10mm |
| Thickness 0.8mm | | | Thickness 10mm Min. | | |

- (3) Use separate thermal insulation pipes for gas and liquid refrigerant pipes.

9. Checking for Gas Leakage

- (1) Check for leakage of gas after air purging
- (2) See the sections on air purges and gas leak checks in the installation manual for the outdoor unit.

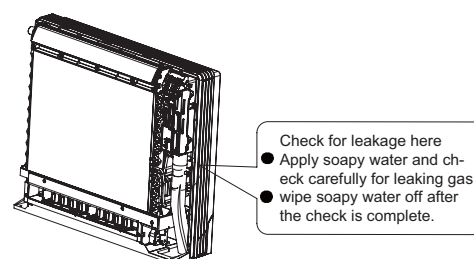

10. Attaching the Connection Pipe

- Attach the pipe after checking for gas leakage, described above.
- (1) Cut the insulated portion of the on-site piping, matching it up with the connecting portion.
- (2) Secure the slit on the refrigerant piping side with the butt joint on the auxiliary piping using the tape, making sure there are no gaps.
- (3) Wrap the slit and butt joint with the included insulation sheet, making sure there are no gaps.

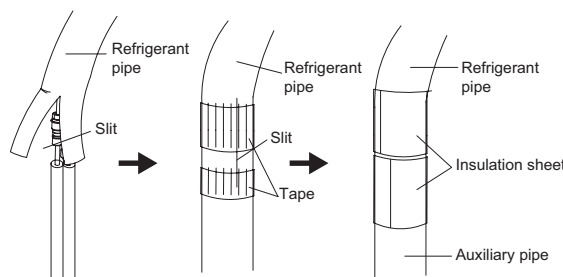

⚠ CAUTION

- (1) Insulate the joint of the pipes securely. Incomplete insulation may lead to water leakage.
- (2) Push the pipe inside so it does not place undue force on the front grille.

11. Connecting the Drain Hose

Insert the supplied C drain hose into the socket of the drain pan. Fully insert the drain hose until it adheres to a seat of the socket.

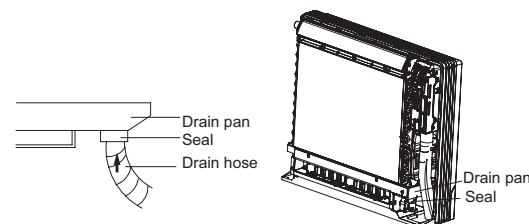

12. Wiring

With a Multi indoor unit, install as described in the installation manual supplied with the Multi outdoor unit.

- Live the sensor securing plate, remove the front metal plate cover, and connect the branch wiring to the terminal block.
- (1) Strip wire ends (15mm)
- (2) Match wire colours with terminal numbers on indoor and outdoor units terminal blocks and firmly screw wires to the corresponding terminals.
- (3) Connect the earth wires to the corresponding terminals.
- (4) Pull wires to make sure that they are securely latched up, then retain wires with wire retainer.
- (5) In case of connecting to an adapter system, Run the remote controller cable and attach the S21. (Refer to 11. When connecting go an system.)

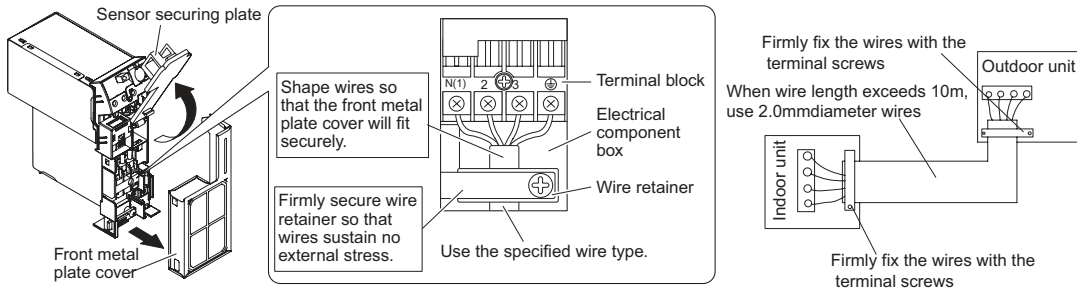

CAUTION

- (1) Do not use tapped wires, stranded wires, extensioncords, or starburst connections, as they may cause overheating, electrical shock, or fire.
- (2) Do not use locally purchased electrical parts inside the product. (Do not branch the power for the drain pump, etc, from the terminal block.) Doing so may cause electric shock or fire.)

8.3 Outdoor Unit Installation

1. Where to Install Outdoor Unit

- The foundation must be solid enough to bear the weight and vibration unit.
- The space around the units is adequate for ventifation.
- The location is not close to any flammable gases.
- The location is sufficiently isolated so that the running noise and the hot exhaust air do not disturb the users or their neighbors.
- Easy access to check and to maintain.
- Ensure the spaces indicated by arrows from the wall, ceiling, fence, or other obstacies.

CAUTION

Installation in the following places may cause problems. If it is unavoidable to use such places, consult with your distributor or dealer.

- A place with machine oil.
- A saline place such as a place very close to a seashore.
- A place with sulphur gas.
- A place where high-frequency waves are generated by radio equipment, welder and medical equipment.

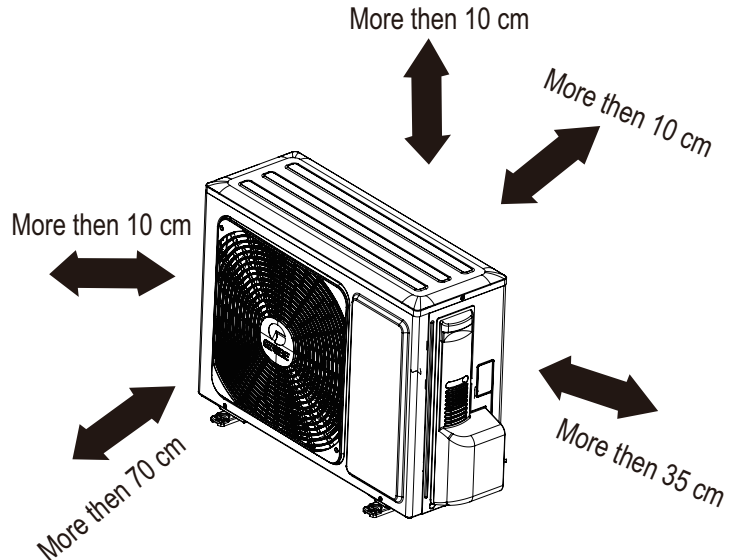

2. Fix the Support of Outdoor Unit(select it according to the actual installation situation)

- (1) Select installation location according to the house structure.
- (2) Fix the support of outdoor unit on the selected location with expansion screws.

Note:

- (1) Take sufficient protective measures when installing the outdoor unit.
- (2) Make sure the support can withstand at least four times the unit weight.
- (3) The outdoor unit should be installed at least 3cm above the floor in order to install drain joint.
- (4) For the unit with cooling capacity of 2300W~5000W, 6 expansion screws are needed; for the unit with cooling capacity of 6000W~8000W, 8 expansion screws are needed; for the unit with cooling capacity of 10000W~16000W, 10 expansion screws are needed.

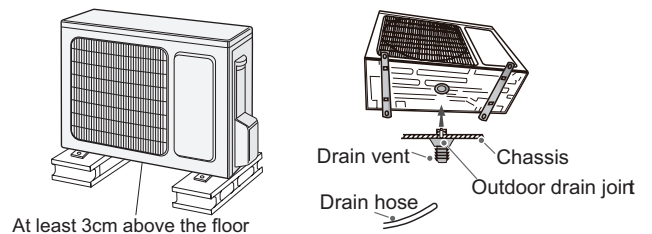

2. Install Drain Joint(Only for cooling and heating unit)

- Connect the outdoor drain joint into the hole on the chassis.
- Connect the drain hose into the drain vent.

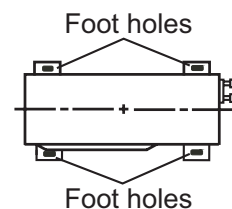

3. Fix Outdoor Unit

- Place the outdoor unit on the support.
- Fix the foot holes of outdoor unit with bolts.

4. Fix Outdoor Unit

- Remove the screw on the right handle of outdoor unit and then remove the handle.
- Remove the screw cap of valve and aim the pipe joint at the bellmouth of pipe.
- Pretightening the union nut with hand.
- Tighten the union nut with torque wrench .

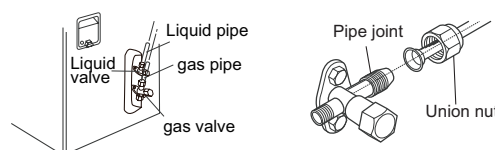
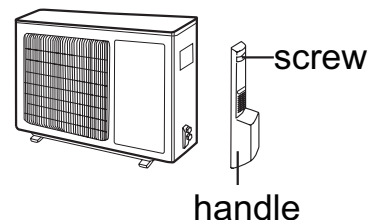

Refer to the following table for wrench moment of force:

| Flare nut tightening torque | | |
|-----------------------------|-----------|-------------|
| Gas side | | Liquid side |
| 12K | 18K | 12K/18K |
| 3/8 inch | 1/2 inch | 1/4 inch |
| 31-35 N.m | 50-55 N.m | 15-20 N.m |

5. Connect Outdoor Electric Wire

- Remove the wire clip; connect the power connection wire to the wiring terminal according to the color; fix them with screws.

- Fix the power connection wire with wire clip.

⚠ Note:

- After tightening the screw, pull the power cord slightly to check if it is firm.
- Never cut the power connection wire to prolong or shorten the distance.

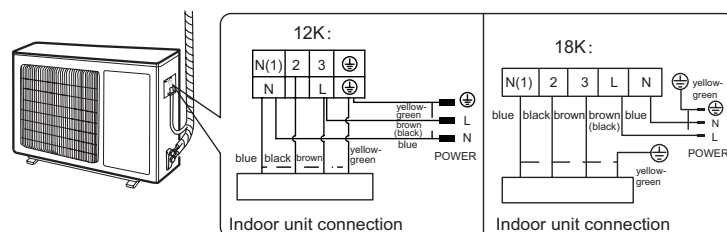

8.4 Vacuum Pumping and Leak Detection

1. Use Vacuum Pump

- Remove the valve caps on the liquid valve and gas valve and the nut of refrigerant charging vent.
- Connect the charging hose of piezometer to the refrigerant charging vent of gas valve and then connect the other charging hose to the vacuum pump.
- Open the piezometer completely and operate for 10-15min to check if the pressure of piezometer remains in -0.1MPa.
- Close the vacuum pump and maintain this status for 1-2min to check if the pressure of piezometer remains in -0.1MPa. If the pressure decreases, there may be leakage.
- Remove the piezometer, open the valve core of liquid valve and gas valve completely with inner hexagon spanner.
- Tighten the screw caps of valves and refrigerant charging vent.

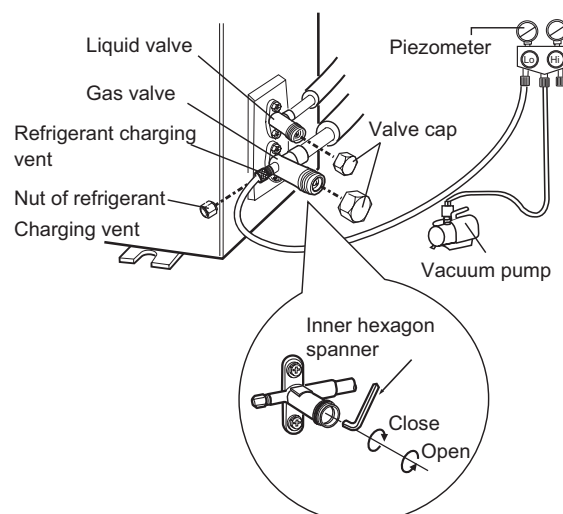

2. Leakage Detection

(1) With leakage detector:

Check if there is leakage with leakage detector.

(2) With soap water:

If leakage detector is not available, please use soap water for leakage detection. Apply soap water at the suspected position and keep the soap water for more than 3min. If there are air bubbles coming out of this position, there's a leakage.

8.5 Check after Installation and Test Operation

1. Check after Installation

Check according to the following requirement after finishing installation.

| NO. | Items to be checked | Possible malfunction |
|-----|--|---|
| 1 | Has the unit been installed firmly? | The unit may drop, shake or emit noise. |
| 2 | Have you done the refrigerant leakage test? | It may cause insufficient cooling (heating) capacity. |
| 3 | Is heat insulation of pipeline sufficient? | It may cause condensation and water dripping. |
| 4 | Is water drained well? | It may cause condensation and water dripping. |
| 5 | Is the voltage of power supply according to the voltage marked on the nameplate? | It may cause malfunction or damage the parts. |
| 6 | Is electric wiring and pipeline installed correctly? | It may cause malfunction or damage the parts. |
| 7 | Is the unit grounded securely? | It may cause electric leakage. |
| 8 | Does the power cord follow the specification? | It may cause malfunction or damage the parts. |
| 9 | Is there any obstruction in air inlet and air outlet? | It may cause insufficient cooling (heating). |
| 10 | The dust and sundries caused during installation are removed? | It may cause malfunction or damaging the parts. |
| 11 | The gas valve and liquid valve of connection pipe are open completely? | It may cause insufficient cooling (heating) capacity. |

2. Test Operation

(1) Preparation of test operation

- The client approves the air conditioner installation.
- Specify the important notes for air conditioner to the client.

(2) Method of test operation

- Put through the power, press ON/OFF button on the remote controller to start operation.
- Press MODE button to select AUTO, COOL, DRY, FAN and HEAT to check whether the operation is normal or not.
- If the ambient temperature is lower than 16°C , the air conditioner can't start cooling.

9. Maintenance

9.1 Error Code List

| Malfunction and Mode Display Sheet | | |
|---|----------------------|----------|
| Malfunction name | Malfunction type | Double 8 |
| Zero-cross detection circuit malfunction | Hardware malfunction | U8 |
| Malfunction protection of jumper cap | Hardware malfunction | C5 |
| No feedback of indoor motor | Hardware malfunction | H6 |
| Indoor ambient temperature sensor is open/short- circuited | Hardware malfunction | F1 |
| Indoor evaporator temperature sensor is open/short-circuited | Hardware malfunction | F2 |
| Liquid valve temperature sensor is open/short-circuited | Hardware malfunction | b5 |
| Gas valve temperature sensor is open/short-circuited | Hardware malfunction | b7 |
| Module temperature sensor is open/short-circuited | Hardware malfunction | P7 |
| Outdoor ambient temperature sensor is open/short- circuited | Hardware malfunction | F3 |
| Outdoor condenser inlet pipe temperature sensor is open/short- circuited | Hardware malfunction | A5 |
| Outdoor condenser middle pipe temperature sensor is open/short- circuited | Hardware malfunction | F4 |
| Outdoor condenser outlet pipe temperature sensor is open/short- circuited | Hardware malfunction | A7 |
| Outdoor discharge temperature sensor is open/short- circuited | Hardware malfunction | F5 |
| Communication malfunction of indoor unit and outdoor unit | Hardware malfunction | E6 |
| Compressor phase current circuit detection malfunction | Hardware malfunction | U1 |
| Compressor demagnetization protection | Hardware malfunction | HE |
| DC busbar voltage drop malfunction | Hardware malfunction | U3 |
| Module temperature protection | Hardware malfunction | P8 |
| shortage of freon or blockage protection for the system | Hardware malfunction | F0 |
| Capacitor charging malfunction | Hardware malfunction | PU |
| High voltage protection for the system | Hardware malfunction | E1 |
| Low voltage protection for the system | Hardware malfunction | E3 |
| Compressor blockage | Hardware malfunction | LE |
| Drive module reset | Hardware malfunction | P0 |
| Overspeed | Hardware malfunction | LF |
| Drive board ambient temperature sensor malfunction | Hardware malfunction | PF |
| AC contactor protection | Hardware malfunction | P9 |
| Temperature drift protection | Hardware malfunction | PE |
| Sensor connection protection | Hardware malfunction | Pd |
| Drive board communication malfunction | Hardware malfunction | P6 |
| Compressor heat overload protection | Hardware malfunction | H3 |
| Indoor unit and outdoor unit do not match | Hardware malfunction | LP |
| Memory chip malfunction | Hardware malfunction | EE |
| Wrong connection of communication cable or expansion valve malfunction | Hardware malfunction | dn |
| Complete unit current detection malfunction | Hardware malfunction | U5 |
| Wrong connection of communication cable or expansion valve malfunction detection mode | Running mode | dd |
| Mode conflict | Running mode | E7 |

| | | | |
|---|--|------------------------------------|----|
| Refrigerant recovery mode | Running mode | Fo | |
| Defrosting or oil return in heating mode | Running mode | H1 | |
| Rating cooling or heating | Running mode | P1 | |
| Max cooling or heating | Running mode | P2 | |
| Middle cooling or heating | Running mode | P3 | |
| Min cooling or heating | Running mode | P0 | |
| Compressor losing of synchronism | Displayed on the remote controller in 200s; display on the nixie tube after 200s | H7 | |
| Compressor start failure | | Lc | |
| High discharge temperature protection of compressor | | E4 | |
| Overload protection | | E8 | |
| Complete unit overcurrent protection | | E5 | |
| Phase current overcurrent protection | | P5 | |
| Module current protection | | H5 | |
| 4-way valve commutation malfunction | | U7 | |
| Complete unit current protection with limiting frequency or lowing down frequency | | Displayed on the remote controller | F8 |
| Module current protection with limiting frequency or lowing down frequency | | Displayed on the remote controller | En |
| Overhigh discharge with limiting frequency or lowing down frequency | Displayed on the remote controller | F9 | |
| Freeze protection with limiting frequency or lowing down frequency | Displayed on the remote controller | FH | |
| Overload with limiting frequency or lowing down frequency | Displayed on the remote controller | F6 | |
| Module temperature protection with limiting frequency or lowing down frequency | Displayed on the remote controller | EU | |
| Oil return in cooling mode | Displayed on the remote controller | F7 | |
| Cold blow protection | Displayed on the remote controller | E9 | |
| Freeze protection | Displayed on the remote controller | E2 | |
| Malfunction protection of outdoor fan (outdoor fan is blocked or not connected -- if there're dual outdoor fans, L3 indicates fan 1, and LA indicates fan 2). | Hardware malfunction | LA | |
| Malfunction of DC fan/malfunction protection of outdoor fan (outdoor fan is blocked or not connected if there're dual outdoor fans, L3 indicates fan 1, and LA indicates fan 2) | Hardware malfunction | L3 | |

9.2 Troubleshooting for Main Malfunction

(1) Troubleshooting for malfunction of temperature sensor

main check point:

- Whether the temperature sensor is broken or damaged;
- Whether the temperature sensor terminal is loosened or not connected;
- Whether the mainboard is damaged;

Check flow chart:

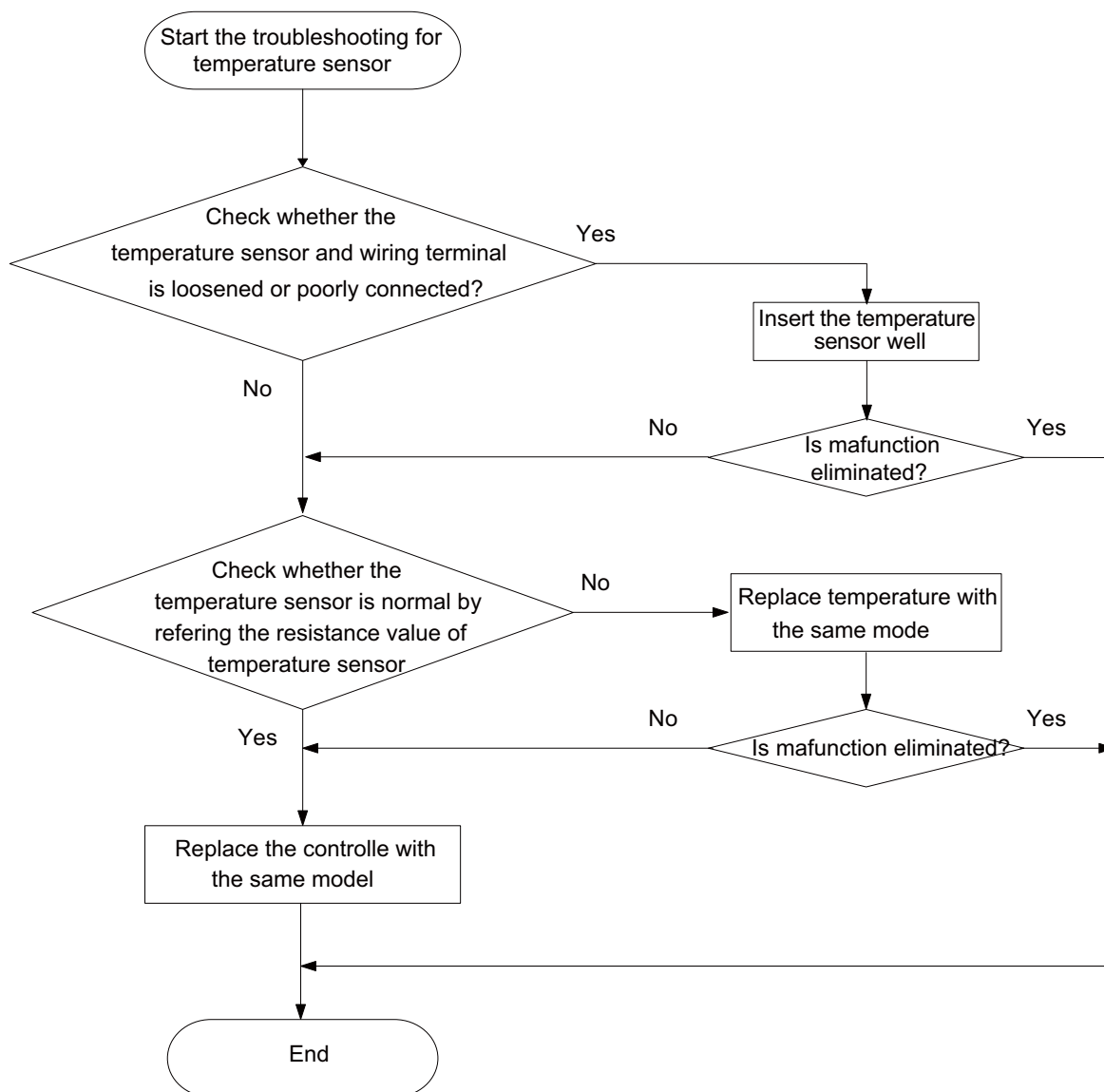

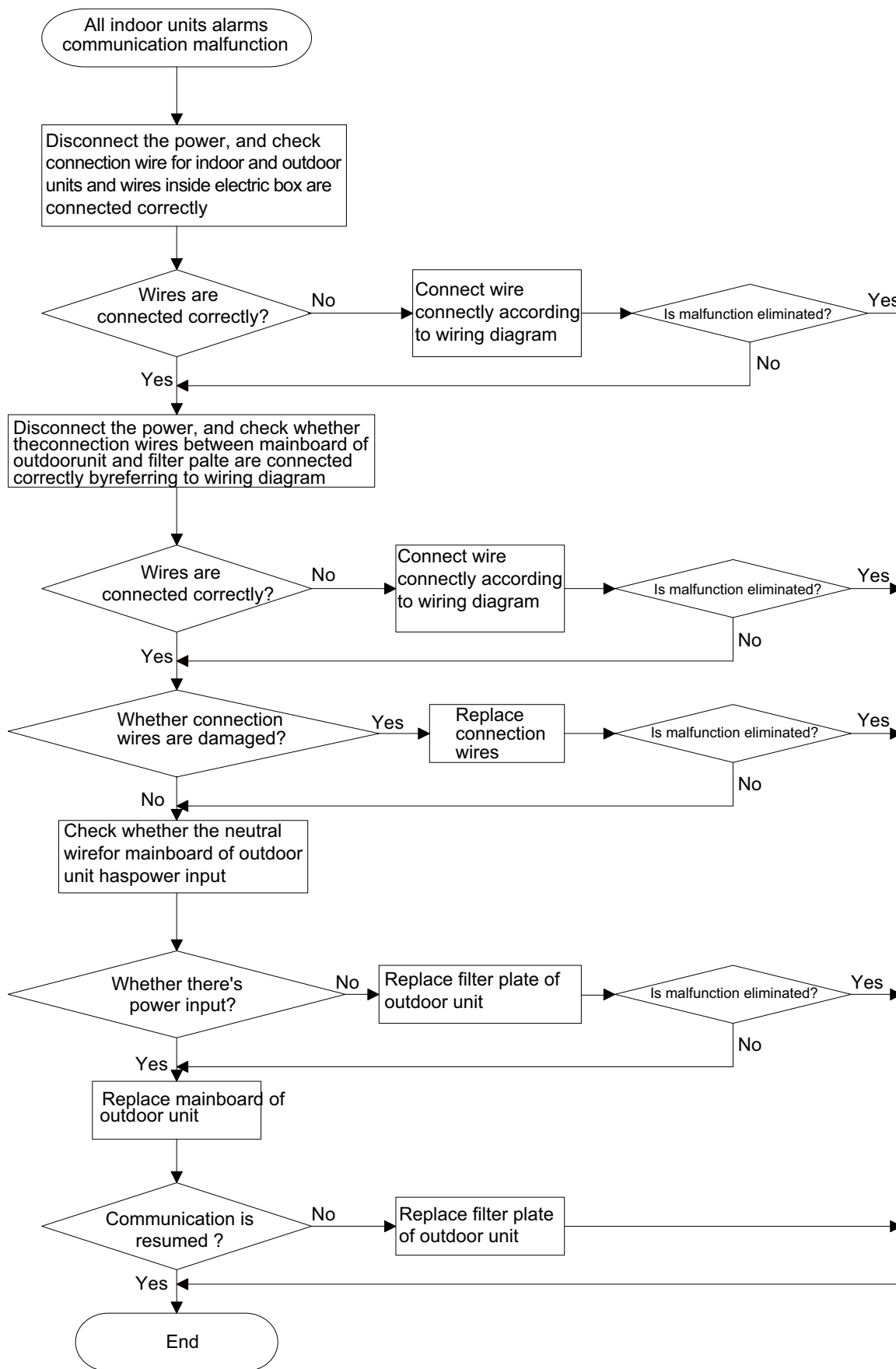

(4) Troubleshooting for H6 malfunction

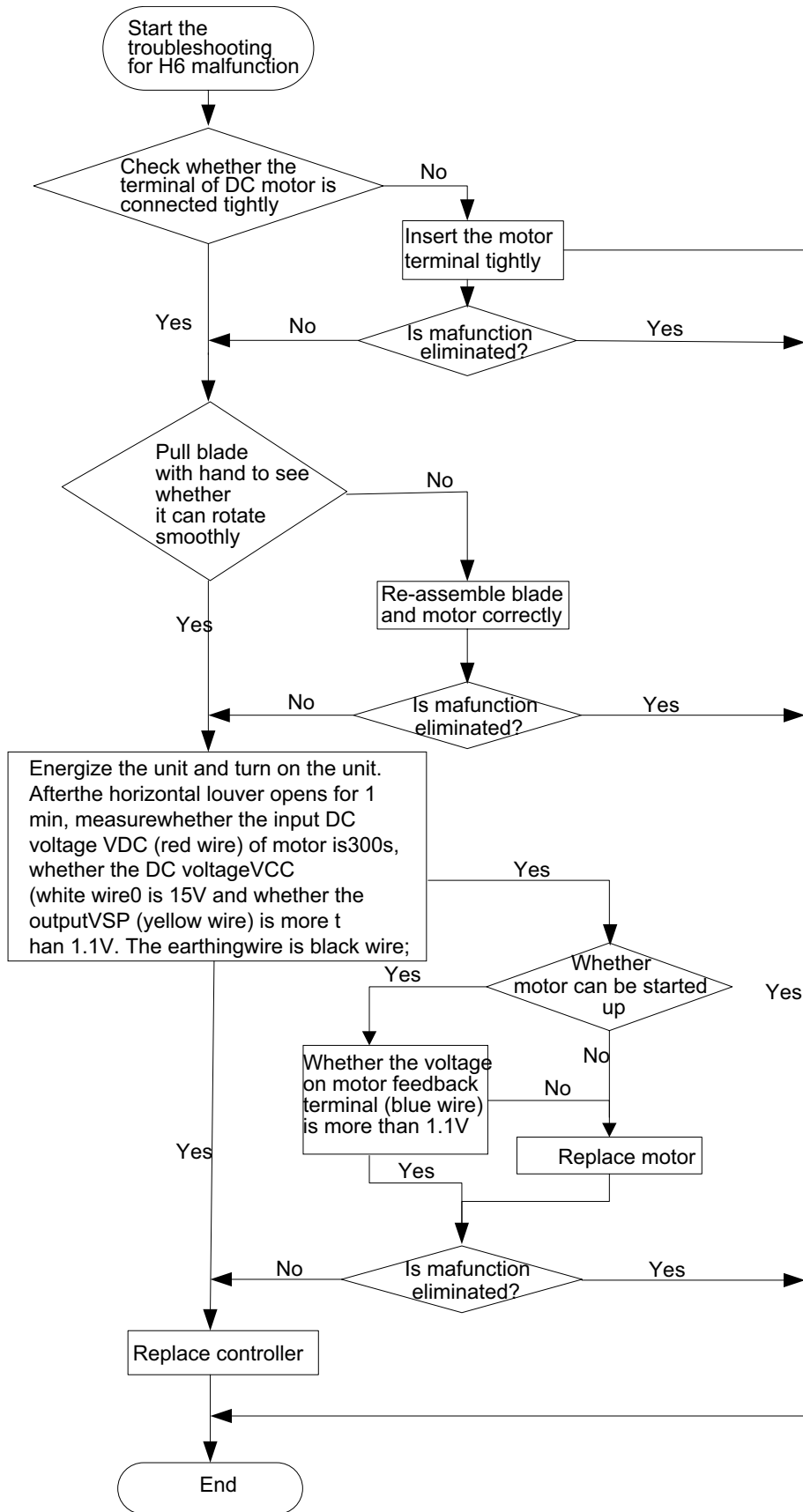

9.3 Maintenance Method for Normal Malfunction

1. Air Conditioner Can't be Started Up

| Possible Causes | Discriminating Method (Air conditioner Status) | Troubleshooting |
|---|---|--|
| No power supply, or poor connection for power plug | After energization, operation indicator isn't bright and the buzzer can't give out sound | Confirm whether it's due to power failure. If yes, wait for power recovery. If not, check power supply circuit and make sure the power plug is connected well. |
| Wrong wire connection between indoor unit and outdoor unit, or poor connection for wiring terminals | Under normal power supply circumstances, operation indicator isn't bright after energization | Check the circuit according to circuit diagram and connect wires correctly. Make sure all wiring terminals are connected firmly |
| Electric leakage for air conditioner | After energization, room circuit breaker trips off at once | Make sure the air conditioner is grounded reliably Make sure wires of air conditioner is connected correctly Check the wiring inside air conditioner. Check whether the insulation layer of power cord is damaged; if yes, place the power cord. |
| Model selection for air switch is improper | After energization, air switch trips off | Select proper air switch |
| Malfunction of remote controller | After energization, operation indicator is bright, while no display on remote controller or buttons have no action. | Replace batteries for remote controller Repair or replace remote controller |

2. Poor Cooling (Heating) for Air Conditioner

| Possible Causes | Discriminating Method (Air conditioner Status) | Troubleshooting |
|--|---|---|
| Set temperature is improper | Observe the set temperature on remote controller | Adjust the set temperature |
| Rotation speed of the IDU fan motor is set too low | Small wind blow | Set the fan speed at high or medium |
| Filter of indoor unit is blocked | Check the filter to see it's blocked | Clean the filter |
| Installation position for indoor unit and outdoor unit is improper | Check whether the installation position is proper according to installation requirement for air conditioner | Adjust the installation position, and install the rainproof and sunproof for outdoor unit |
| Refrigerant is leaking | Discharged air temperature during cooling is higher than normal discharged wind temperature; Discharged air temperature during heating is lower than normal discharged wind temperature; Unit's pressure is much lower than regulated range | Find out the leakage causes and deal with it. Add refrigerant. |
| Malfunction of 4-way valve | Blow cold wind during heating | Replace the 4-way valve |
| Malfunction of capillary | Discharged air temperature during cooling is higher than normal discharged wind temperature; Discharged air temperature during heating is lower than normal discharged wind temperature; Unit's pressure is much lower than regulated range. If refrigerant isn't leaking, part of capillary is blocked | Replace the capillary |
| Flow volume of valve is insufficient | The pressure of valves is much lower than that stated in the specification | Open the valve completely |
| Malfunction of horizontal louver | Horizontal louver can't swing | Refer to point 3 of maintenance method for details |
| Malfunction of the IDU fan motor | The IDU fan motor can't operate | Refer to troubleshooting for H6 for maintenance method in details |
| Malfunction of the ODU fan motor | The ODU fan motor can't operate | Refer to point 4 of maintenance method for details |
| Malfunction of compressor | Compressor can't operate | Refer to point 5 of maintenance method for details |

3. Horizontal Louver Can't Swing

| Possible Causes | Discriminating Method (Air conditioner Status) | Troubleshooting |
|---|--|--|
| Wrong wire connection, or poor connection | Check the wiring status according to circuit diagram | Connect wires according to wiring diagram to make sure all wiring terminals are connected firmly |
| Stepping motor is damaged | Stepping motor can't operate | Repair or replace stepping motor |
| Main board is damaged | Others are all normal, while horizontal louver can't operate | Replace the main board with the same model |

4. ODU Fan Motor Can't Operate

| Possible causes | Discriminating method (air conditioner status) | Troubleshooting |
|---|---|--|
| Wrong wire connection, or poor connection | Check the wiring status according to circuit diagram | Connect wires according to wiring diagram to make sure all wiring terminals are connected firmly |
| Capacity of the ODU fan motor is damaged | Measure the capacity of fan capacitor with an universal meter and find that the capacity is out of the deviation range indicated on the nameplate of fan capacitor. | Replace the capacity of fan |
| Power voltage is a little low or high | Use universal meter to measure the power supply voltage. The voltage is a little high or low | Suggest to equip with voltage regulator |
| Motor of outdoor unit is damaged | When unit is on, cooling/heating performance is bad and ODU compressor generates a lot of noise and heat. | Change compressor oil and refrigerant. If no better, replace the compressor with a new one |

5. Compressor Can't Operate

| Possible causes | Discriminating method (air conditioner status) | Troubleshooting |
|---|---|--|
| Wrong wire connection, or poor connection | Check the wiring status according to circuit diagram | Connect wires according to wiring diagram to make sure all wiring terminals are connected firmly |
| Capacity of compressor is damaged | Measure the capacity of fan capacitor with an universal meter and find that the capacity is out of the deviation range indicated on the nameplate of fan capacitor. | Replace the compressor capacitor |
| Power voltage is a little low or high | Use universal meter to measure the power supply voltage. The voltage is a little high or low | Suggest to equip with voltage regulator |
| Coil of compressor is burnt out | Use universal meter to measure the resistance between compressor terminals and it's 0 | Repair or replace compressor |
| Cylinder of compressor is blocked | Compressor can't operate | Repair or replace compressor |

6. Air Conditioner is Leaking

| Possible causes | Discriminating method (air conditioner status) | Troubleshooting |
|-----------------------|---|---|
| Drain pipe is blocked | Water leaking from indoor unit | Eliminate the foreign objects inside the drain pipe |
| Drain pipe is broken | Water leaking from drain pipe | Replace drain pipe |
| Wrapping is not tight | Water leaking from the pipe connection place of indoor unit | Wrap it again and bundle it tightly |

7. Abnormal Sound and Vibration

| Possible causes | Discriminating method (air conditioner status) | Troubleshooting |
|---|--|--|
| When turn on or turn off the unit, the panel and other parts will expand and there's abnormal sound | There's the sound of "PAPA" | Normal phenomenon. Abnormal sound will disappear after a few minutes. |
| When turn on or turn off the unit, there's abnormal sound due to flow of refrigerant inside air conditioner | Water-running sound can be heard | Normal phenomenon. Abnormal sound will disappear after a few minutes. |
| Foreign objects inside the indoor unit or there're parts touching together inside the indoor unit | There's abnormal sound fro indoor unit | Remove foreign objects. Adjust all parts' position of indoor unit, tighten screws and stick damping plaster between connected parts |
| Foreign objects inside the outdoor unit or there're parts touching together inside the outdoor unit | There's abnormal sound fro outdoor unit | Remove foreign objects. Adjust all parts' position of outdoor unit, tighten screws and stick damping plaster between connected parts |
| Short circuit inside the magnetic coil | During heating, the way valve has abnormal electromagnetic sound | Replace magnetic coil |
| Abnormal shake of compressor | Outdoor unit gives out abnormal sound | Adjust the support foot mat of compressor, tighten the bolts |
| Abnormal sound inside the compressor | Abnormal sound inside the compressor | If add too much refrigerant during maintenance, please reduce refrigerant properly. Replace compressor for other circumstances. |

10. Exploded View and Parts List

10.1 Indoor Unit

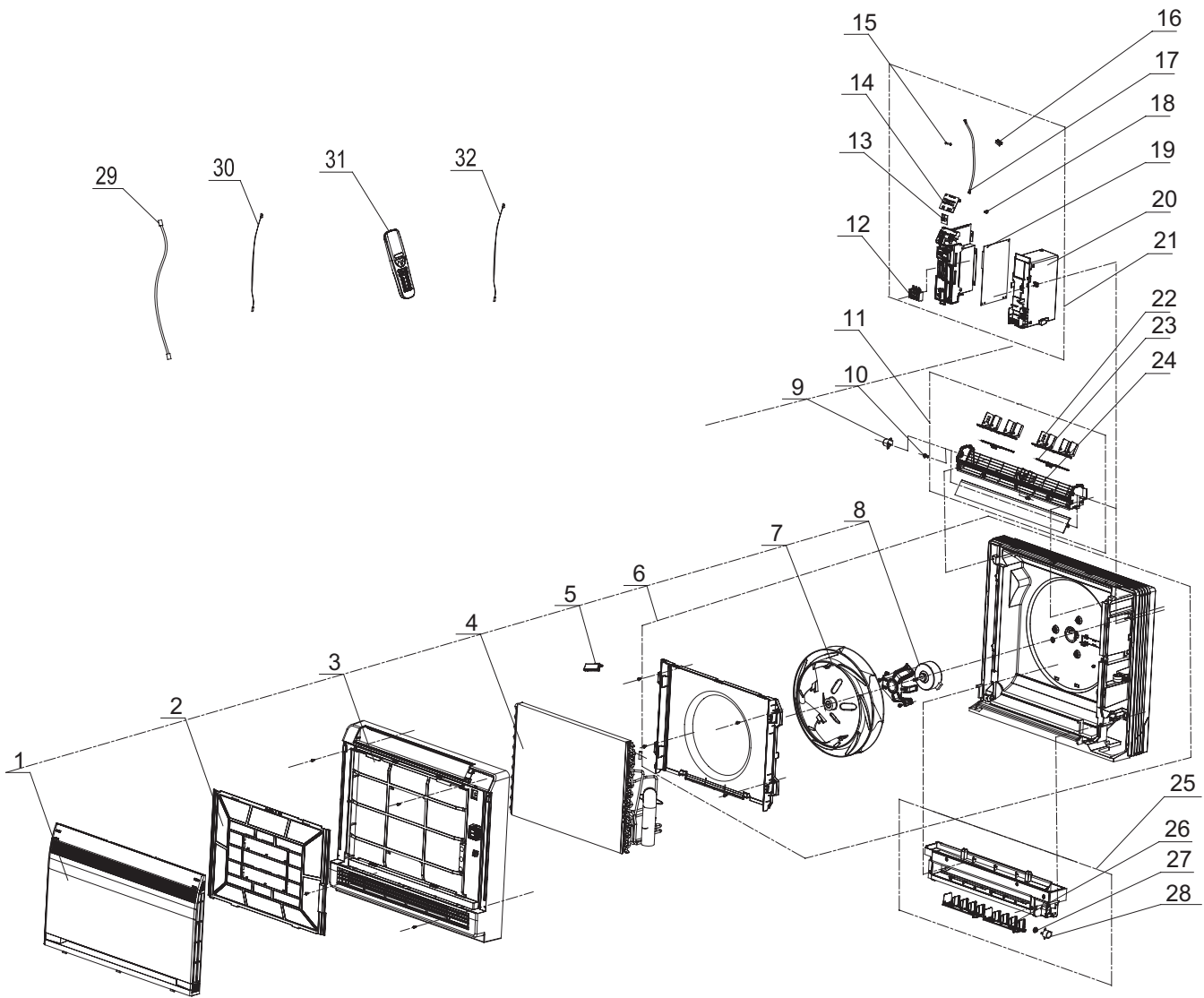

The component is only for reference; please refer to the actual product.

| NO. | Description | Part Code | | Qty |
|-----|-------------------------|-------------------|-------------------|-----|
| | | GEH12AA-K3DNA1D/I | GEH18AA-K3DNA1D/I | |
| | Product Code | CV010N02600 | CV010N02400 | |
| 1 | Front Panel Assy | 20012756 | 20012756 | 1 |
| 2 | Filter Sub-Assy | 11122139 | 11122139 | 1 |
| 3 | Front Case Assy | 20012601 | 20012601 | 1 |
| 4 | Evaporator Assy | 01100100160 | 01100100164 | 1 |
| 5 | Cold Plasma Generator | 1114001604 | 1114001604 | 1 |
| 6 | Rear Case Assy | 000001000051 | 22202462 | 1 |
| 7 | Centrifugal Fan | 10312005 | 10312005 | 1 |
| 8 | Fan Motor | 1570410001201 | 15704100012 | 1 |
| 9 | SteppingMotor | 1521210101 | 1521210101 | 1 |
| 10 | Crank | 73012005 | 73012005 | 1 |
| 11 | Swing Assy | 10102042 | 10102042 | 1 |
| 12 | Terminal Board | 42011233 | 42011233 | 1 |
| 13 | Switch Board | 30112007 | 30112007 | 1 |
| 14 | Display Board | 30568131 | 30568131 | 1 |
| 15 | Fuse | 46010030 | 46010030 | 1 |
| 16 | Radiator | / | / | / |
| 17 | Signal Wire | 4003004202 | 4003004202 | 1 |
| 18 | Jumper | 4202300112 | 4202300114 | 1 |
| 19 | Main Board | 300002000631 | 300002000631 | 1 |
| 20 | Electric Box | 20112116 | 20112116 | 1 |
| 21 | Electric Box Assy | 100002002951 | 100002002386 | 1 |
| 22 | Air Louver (upper) | 10512143 | 10512143 | 2 |
| 23 | Swing Lever | 10582096 | 10582096 | 1 |
| 24 | Shaft of Guide Louver | 10542020 | 10542020 | 1 |
| 25 | Water Tray Assy | 20182141 | 20182141 | 1 |
| 26 | Air Louver (lower) | 10512144 | 10512144 | 1 |
| 27 | Axis (lower step motor) | 10542034 | 10542034 | 1 |
| 28 | SteppingMotor | 1521210805 | 1521210101 | 1 |
| 29 | Connecting Cable | 4002052317 | 4002052317 | 0 |
| 30 | Temperature Sensor | 3900004508 | 3900004508 | 1 |
| 31 | Remote Controller | 305001000111 | 305001000111 | 1 |
| 32 | Temperature Sensor | 390000591 | 390000591 | 1 |

Above data is subject to change without notice.

| NO. | Description | Part Code | Qty |
|-----|-------------------------------|-------------------|-----|
| | | GEH12AA-K3DNA1D/O | |
| | Product Code | CV010W02600 | |
| 1 | Electric Box Assy | 100002002950 | 1 |
| 2 | Electric Box Sub-Assy | 017007000476 | 1 |
| 3 | Main Board | 300027000469 | 1 |
| 4 | Reactor | 43130184 | 1 |
| 5 | Terminal Board | 42010313 | 1 |
| 6 | Wire Clamp | 71010103 | 1 |
| 7 | Front Grill | 22413049 | 1 |
| 8 | Front Panel | 01533034P | 1 |
| 9 | Axial Flow Fan | 10333004 | 1 |
| 10 | Chassis Sub-assy | 017000000126P | 1 |
| 11 | Fan Motor | 1501308506 | 1 |
| 12 | Top Cover Plate | 01253073 | 1 |
| 13 | Motor Support | 0170310403 | 1 |
| 14 | Condenser Assy | 01100200173 | 1 |
| 15 | Rear Grill | 01473009 | 1 |
| 16 | Electronic Expansion Valve | 07133978 | 1 |
| 17 | Cut off Valve | 07133474 | 1 |
| 18 | Big Handle | 262334332 | 1 |
| 19 | Valve | 07100003 | 1 |
| 20 | Valve Support | 0171314201P | 1 |
| 21 | Right Side Plate Sub-Assy | 0130317801 | 1 |
| 22 | 4-Way Valve Assy | 030152000339 | 1 |
| 23 | Clapboard Sub-Assy | 0123338502 | 1 |
| 24 | Magnet Coil | 4300040050 | 1 |
| 25 | Compressor and Fittings | 009001000181 | 1 |
| 26 | Drainage Connector | 06123401 | 1 |
| 27 | Electrical Heater(Compressor) | / | / |
| 28 | Electrical Heater(Chassis) | 7651000414 | 1 |

Above data is subject to change without notice.

| NO. | Description | Part Code | Qty |
|-----|---|-------------------|-----|
| | | GEH18AA-K3DNA1D/O | |
| | | Product Code | |
| | | CV010W02400 | |
| 1 | Front Grill | 22413045 | 1 |
| 2 | Front Panel | 01535013P | 1 |
| 3 | Drainage Connector | 06123401 | 1 |
| 4 | Chassis Sub-assy | 02803270P | 1 |
| 5 | Drainage hole Cap | 06813401 | 1 |
| 6 | Compressor and fittings | 00105246G | 1 |
| 7 | Magnet Coil | 4300040045 | 1 |
| 8 | 4-Way Valve Assy | 03015200069 | 1 |
| 9 | Cut off Valve Assy 1/2 | 07133774 | 1 |
| 10 | Cut off Valve Sub-Assy | 07133058 | 1 |
| 11 | Valve support assy | 01715010P | 1 |
| 12 | Right Side Plate | 0130509402P | 1 |
| 13 | Valve cover | 22245002 | 1 |
| 14 | Handle | 26233053 | 1 |
| 15 | Wiring Clamp | 26115004 | 1 |
| 16 | Electronic Expansion Valve assy | 07133772 | 1 |
| 17 | Electric Expand Valve Fitting | 4300876704 | 1 |
| 18 | Rear Grill | 01473043 | 1 |
| 19 | Condenser Assy | 0116348702 | 1 |
| 20 | Reactor | / | / |
| 21 | Clapboard Assy | 01233153 | 1 |
| 22 | Coping | 012049000007P | 1 |
| 23 | Supporting Board(Condenser) | 01795010 | 1 |
| 24 | Motor Support Sub-Assy | 01705036 | 1 |
| 25 | Fan Motor | 1501506402 | 1 |
| 26 | Axial Flow Fan | 10335008 | 1 |
| 27 | Left Side Plate | 01305093P | 1 |
| 28 | left handle | 2623525404 | 1 |
| 29 | Electric Box Assy | 100002002385 | 1 |
| 30 | Wire Clamp | 71010003 | 1 |
| 31 | Terminal Board | 420101943 | 1 |
| 32 | Electric Box | 20113027 | 1 |
| 33 | Radiator | 49010252 | 1 |
| 34 | Main Board | 30138000672 | 1 |
| 35 | Insulated Board (Cover of Electric Box) | 20113003 | 1 |
| 36 | Temperature Sensor | 3900030901 | 1 |

Above data is subject to change without notice.

11. Removal Procedure

⚠ Warning: Be sure to wait for a minimum of 20 minutes after turning off all power supplies and discharge the refrigerant completely before removal.

11.1 Removal Procedure of Indoor Unit

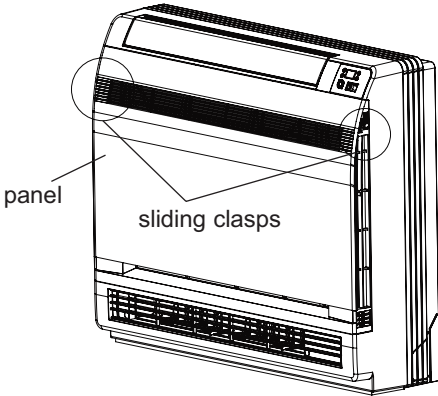
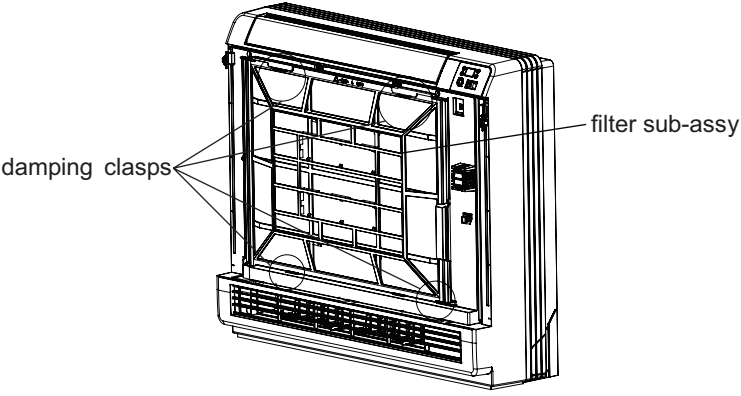
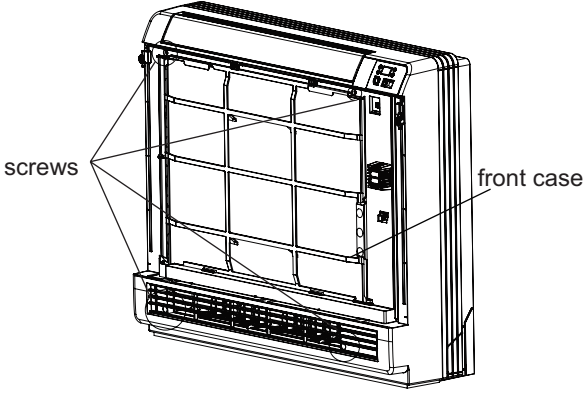
| Steps | Procedure |
|----------------------------------|--|
| <p>1. Remove panel</p> | <p>Pull sliding clasps at both sides of panel, pull out the panel outwards and then move the panel upwards to remove it.</p>  |
| <p>2. Remove filter sub-assy</p> | <p>Pull the damping clasps at upper/lower side of filter sub-assy, and then move the filter sub-assy outwards to remove it.</p>  |
| <p>3. Remove front case</p> | <p>Remove 4 screws fixing the front case, and then pull the front case outwards to remove it.</p>  |

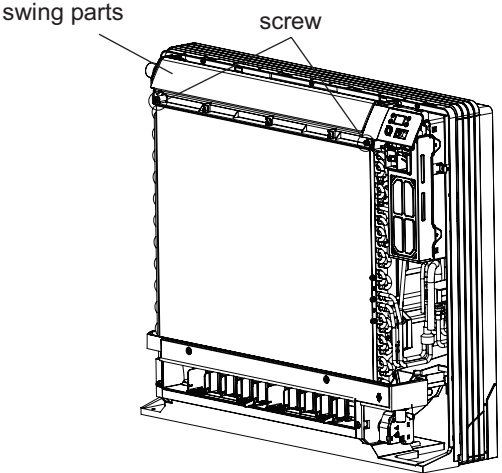
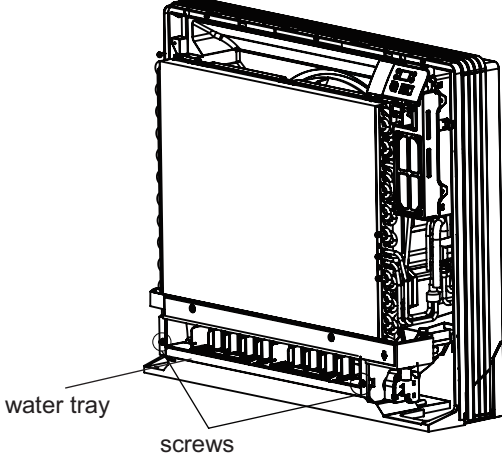
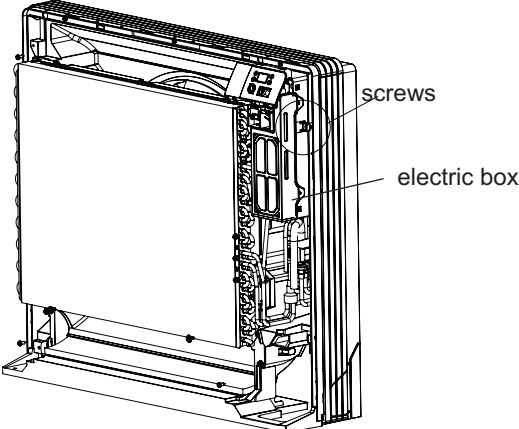
| Steps | Procedure |
|-------------------------------|---|
| <p>4. Remove swing parts</p> | <p>Remove 2 screws fixing the swing parts, and then pull the swing parts outwards to remove it.</p>  |
| <p>5. Remove water tray</p> | <p>Remove 2 screws fixing water tray, and then pull the water tray outwards to remove it.</p>  |
| <p>6. Remove electric box</p> | <p>Remove one screw fixing the electric box, and then pull the electric box outwards to remove it.</p>  |

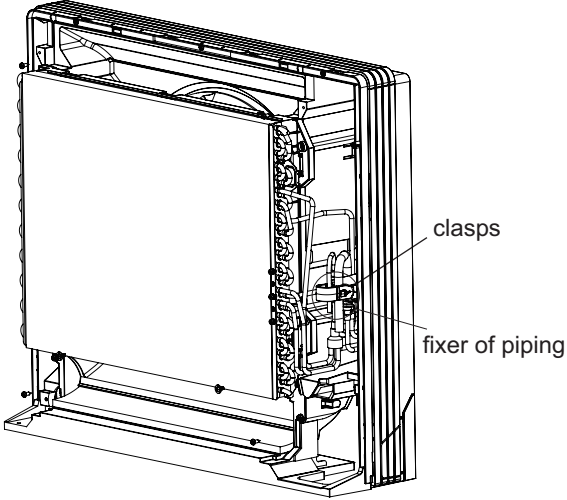
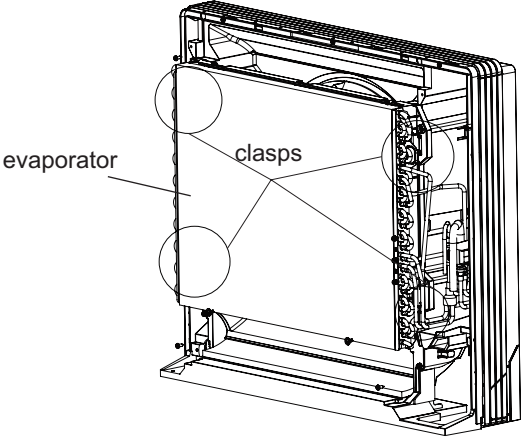
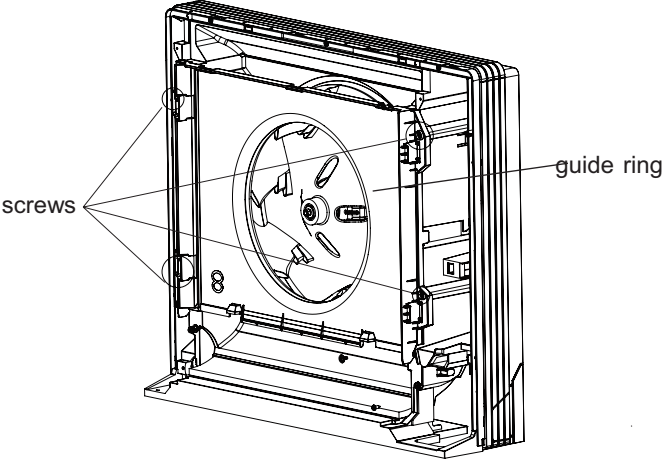
| Steps | Procedure |
|----------------------------------|---|
| <p>7. Remove fixer of piping</p> | <p>Pry out the clasps connecting fixer of piping and bottom case, and then pull the fixer of piping outwards to remove it.</p>  |
| <p>8. Remove evaporator</p> | <p>Pry out the clasps connecting evaporator and bottom case, and then pull the evaporator outwards to remove it.</p>  |
| <p>9. Remove guide ring</p> | <p>Remove 4 screws fixing guide ring, and then pull the guide ring outwards to remove it.</p>  |

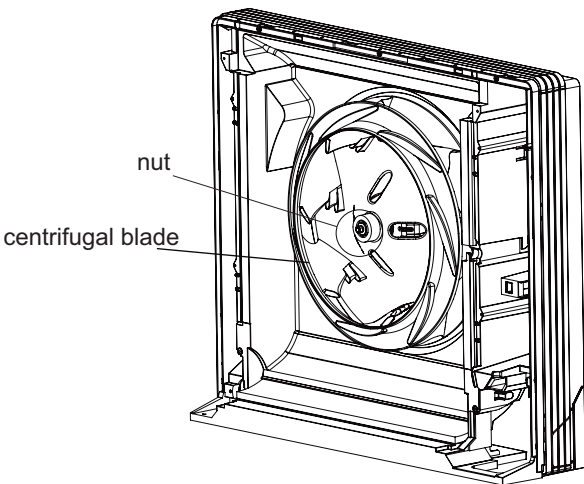
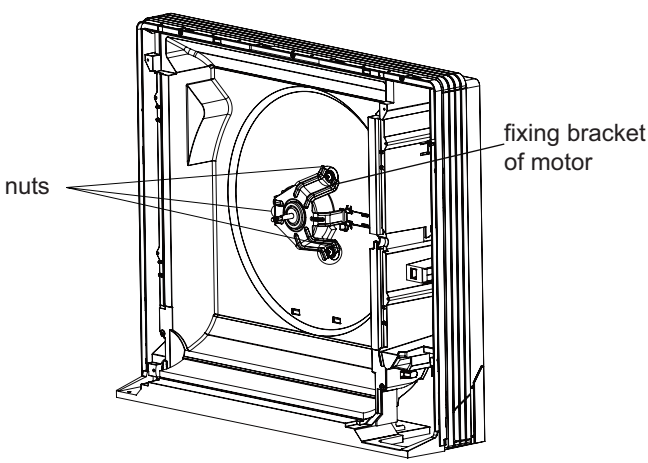
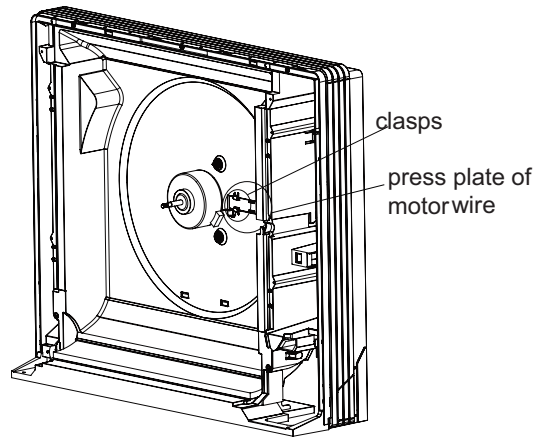
| Steps | Procedure |
|---|--|
| <p>10. Remove centrifugal blade</p> | <p>Remove one nut fixing the centrifugal blade, and then pull the centrifugal blade outwards to remove it.</p>  <p>The diagram shows a centrifugal blade assembly mounted on a motor. A single nut is shown being removed from the blade's mounting point. Labels 'nut' and 'centrifugal blade' point to the respective parts.</p> |
| <p>11. Remove fixing bracket of motor</p> | <p>Remove 3 nuts on fixing bracket of motor, and then pull the fixing bracket of motor outwards to remove it.</p>  <p>The diagram shows the motor's fixing bracket assembly. Three nuts are indicated by lines pointing to their locations on the bracket. Labels 'nuts' and 'fixing bracket of motor' are present.</p> |
| <p>12. Remove press plate of motor wire</p> | <p>Loosen clasps between press plate of motor wire and bottom case, and then pull the press plate of motor wire outwards to remove it.</p>  <p>The diagram shows the motor wire press plate assembly. Two clasps are shown connecting the press plate to the bottom case. Labels 'clasps' and 'press plate of motor wire' are present.</p> |

11.2 Removal Procedure of Outdoor Unit

12K

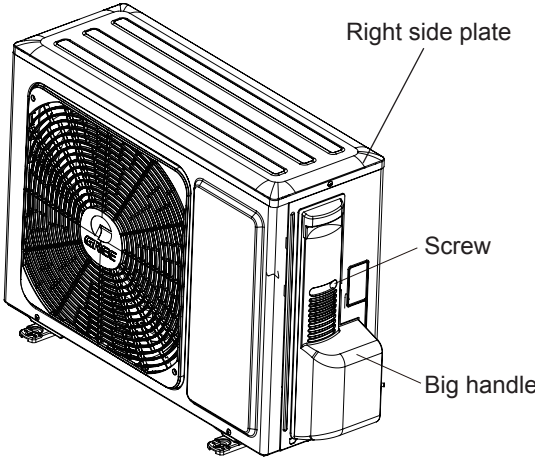
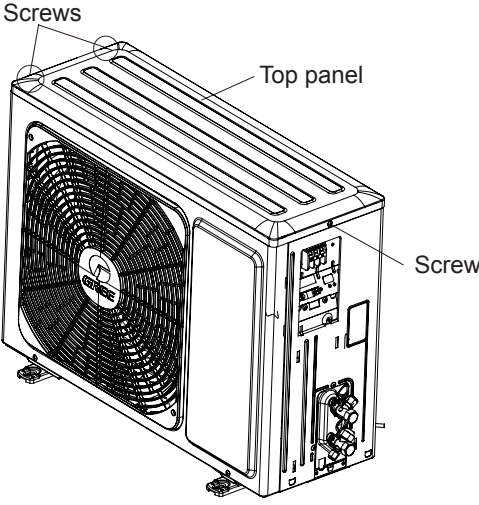
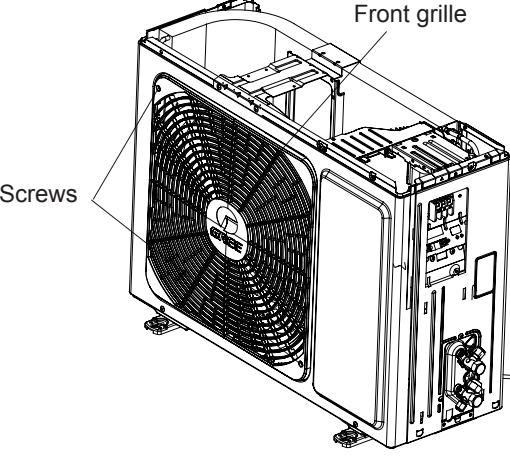
| Steps | Procedure |
|-------------------------------|--|
| <p>1. Remove big handle</p> | <p>Remove the screw fixing big handle; slide out the big handle upwards to make the clasp of big handle separate from the groove of right side plate, and then remove the big handle.</p>  <p>The diagram shows a perspective view of the outdoor unit. A line points to the top edge of the right side panel, labeled 'Right side plate'. Another line points to a screw on the right side panel, labeled 'Screw'. A third line points to the large handle on the right side panel, labeled 'Big handle'.</p> |
| <p>2. Remove top panel</p> | <p>Remove the screws fixing top panel and then remove the top panel.</p>  <p>The diagram shows a perspective view of the outdoor unit with the top panel partially removed. A line points to the screws on the top panel, labeled 'Screws'. Another line points to the top panel itself, labeled 'Top panel'. A third line points to a screw on the right side panel, labeled 'Screw'.</p> |
| <p>3. Remove front grille</p> | <p>Remove connection screws between the front grille and the front panel. Then remove the front grille.</p>  <p>The diagram shows a perspective view of the outdoor unit with the front grille removed. A line points to the front grille, labeled 'Front grille'. Another line points to the screws connecting the grille to the front panel, labeled 'Screws'.</p> |

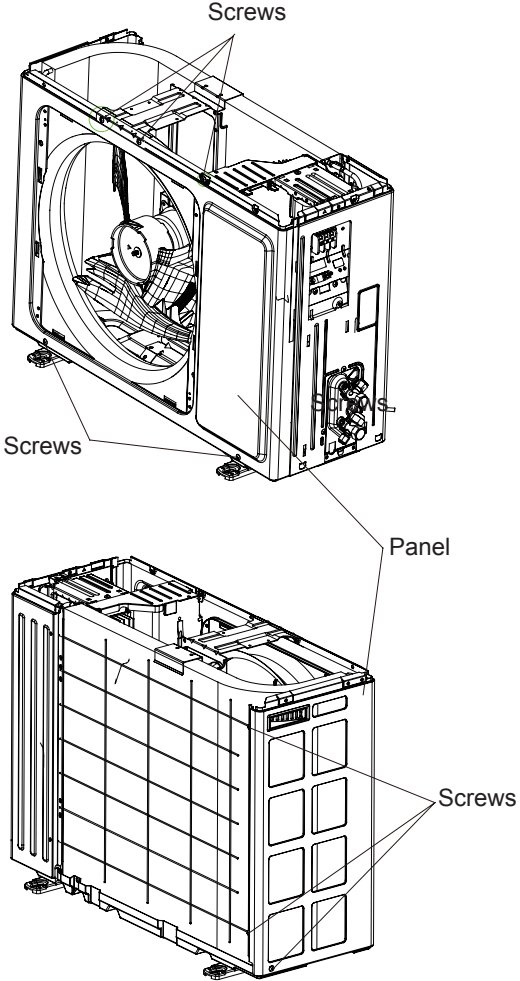
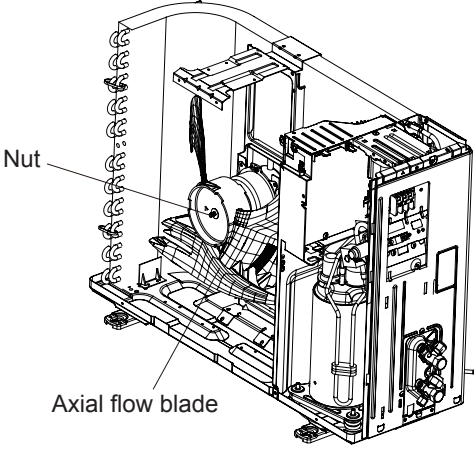
| Steps | Procedure |
|---|--|
| <p data-bbox="126 235 365 266">4. Remove front panel</p> | <p data-bbox="235 360 722 425">Remove the screws fixing front panel, and then remove the front panel.</p>  |
| <p data-bbox="126 1393 414 1423">5. Remove axial flow blade</p> | <p data-bbox="235 1496 722 1561">Remove the nut fixing axial flow blade and then remove the axial flow blade.</p>  |

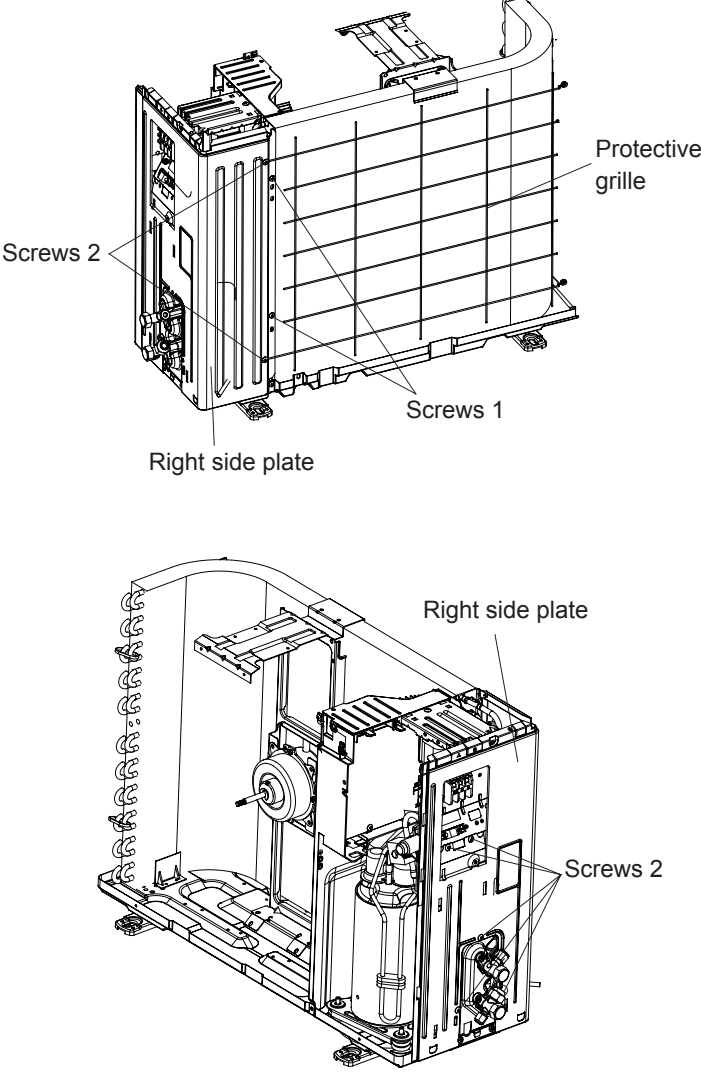
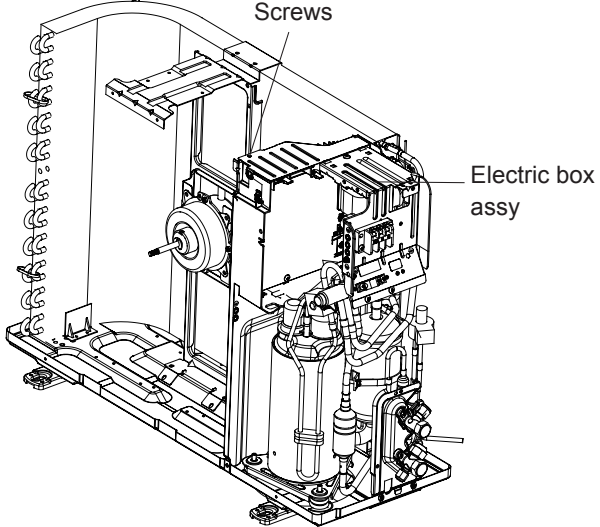
| Steps | Procedure |
|---|---|
| <p data-bbox="134 235 634 264">6. Remove protective grille and right side plate</p> <p data-bbox="240 395 695 482">Remove the screws 1 fixing protective grille and then remove the protective grille.</p> <p data-bbox="240 919 695 978">Remove the screws 2 fixing right side plate and then remove the right side plate.</p> |  <p data-bbox="792 541 894 570">Screws 2</p> <p data-bbox="1385 438 1495 497">Protective grille</p> <p data-bbox="1198 694 1300 722">Screws 1</p> <p data-bbox="938 744 1105 773">Right side plate</p> <p data-bbox="1214 897 1382 926">Right side plate</p> <p data-bbox="1360 1153 1463 1181">Screws 2</p> |
| <p data-bbox="134 1437 440 1465">7. Remove electric box assy</p> | <p data-bbox="240 1552 695 1640">Remove the screws fixing electric box assy ; pull out each wiring terminal; lift the electric box assy upwards to remove it.</p> <p data-bbox="240 1683 695 1808"> Note: When pulling out the wiring terminal, pay attention to loose the clasp and don't pull it so hard. </p>  <p data-bbox="1138 1465 1224 1493">Screws</p> <p data-bbox="1360 1633 1490 1692">Electric box assy</p> |

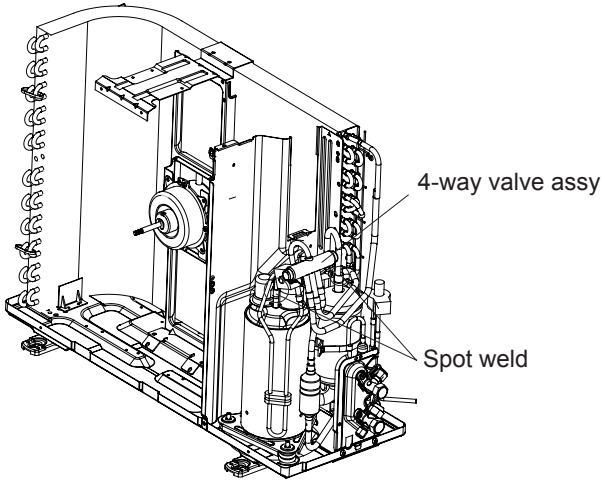
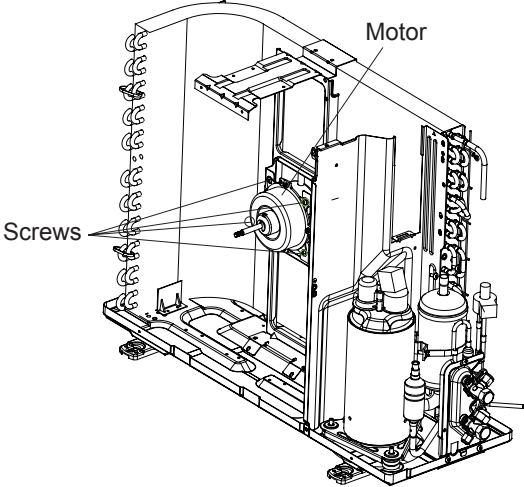
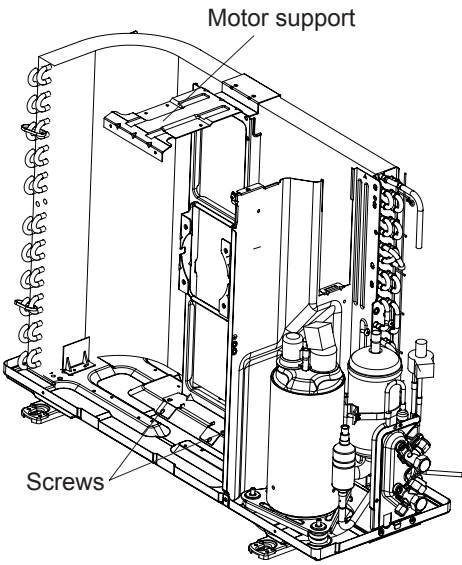
| Steps | Procedure |
|-----------------------------------|---|
| <p>8. Remove 4-way valve assy</p> | <p>Unsolder the spot weld of 4-way valve assy, compressor and condenser, and then remove the 4-way valve assy .</p> <p>Note: When unsoldering the spot weld, wrap the 4-way valve with wet cloth completely to avoid damaging the valve due to high temperature.</p>  |
| <p>9. Remove motor</p> | <p>Remove the screws fixing motor and then remove the motor.</p>  |
| <p>10. Remove motor support</p> | <p>Remove the screws fixing motor support and then remove the motor support.</p>  |

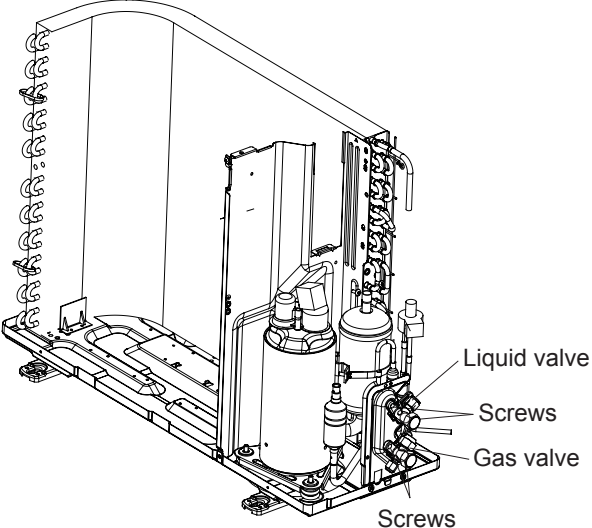
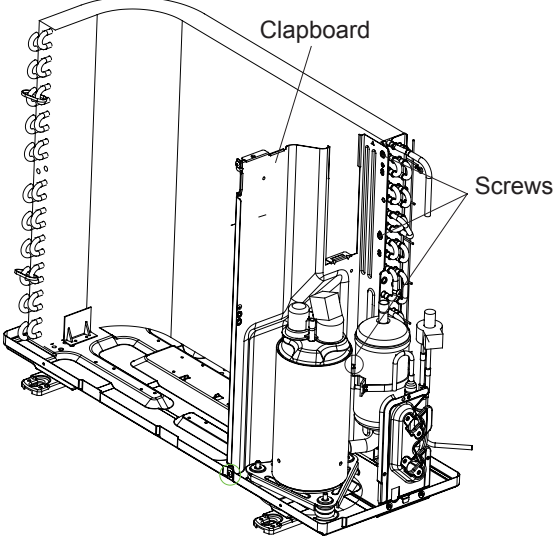
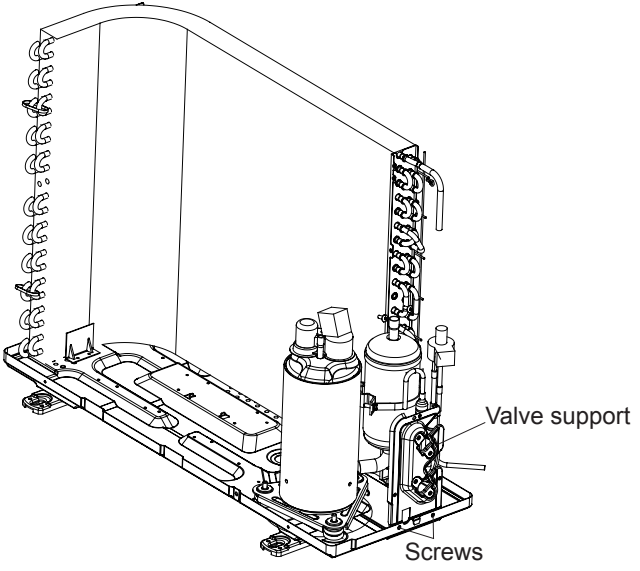
| Steps | Procedure |
|--|--|
| <p>11. Remove gas valve and liquid valve</p> | <p>Remove two screws fixing the gas valve, then remove the gas valve.</p> <p>Remove two screws fixing the liquid valve, then remove the liquid valve.</p>  |
| <p>12. Remove clapboard</p> | <p>Remove the screws fixing clapboard and then remove the clapboard.</p>  |
| <p>13. Remove valve support</p> | <p>Remove the screws fixing valve support and then remove the valve support.</p>  |

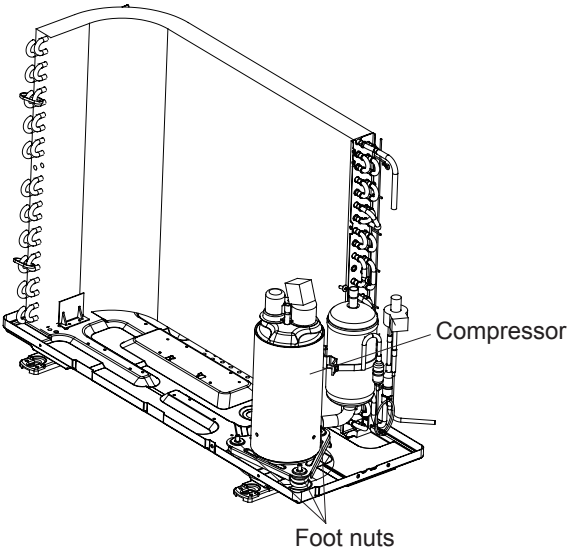
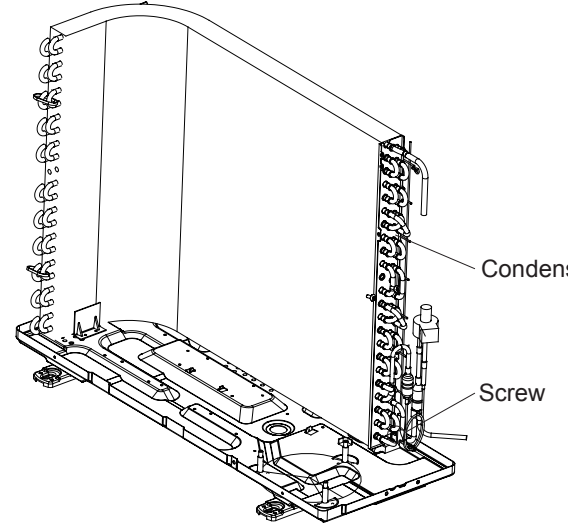
| Steps | Procedure |
|-----------------------|--|
| 14. Remove compressor | <p>Remove 3 foot nuts on compressor, and then remove the compressor.</p> <p>Note: Protect the ports of discharge pipe and suction pipe to avoid foreign objects to enter it.</p>  <p>The diagram shows a compressor unit mounted on a base. Three foot nuts are indicated by lines pointing to the base of the compressor. The compressor itself is a cylindrical unit with various pipes and fittings. The label 'Compressor' points to the main unit, and 'Foot nuts' points to the three mounting points on the base.</p> |
| 15. Remove condenser | <p>Remove one screw fixing the condenser, then remove the condenser.</p>  <p>The diagram shows a condenser unit mounted on a base. One screw is indicated by a line pointing to the base of the condenser. The condenser is a vertical, cylindrical unit with various pipes and fittings. The label 'Condenser' points to the main unit, and 'Screw' points to the one mounting screw on the base.</p> |

18K

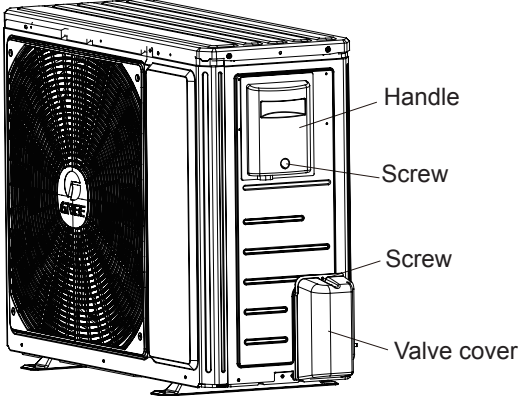
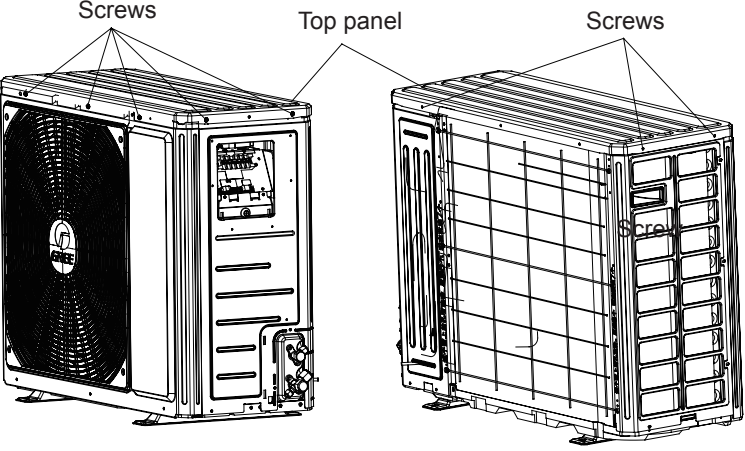
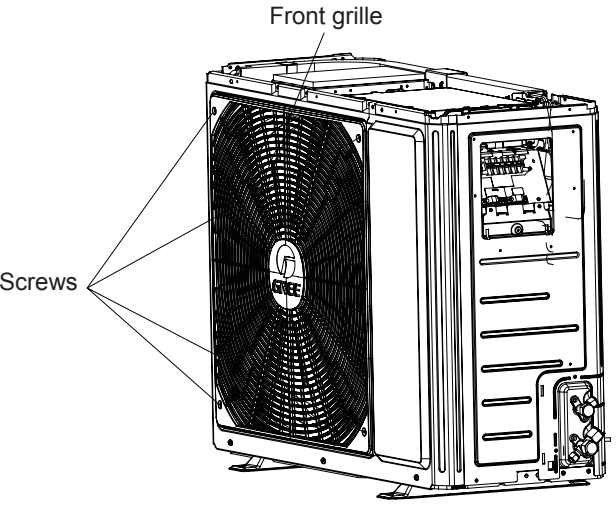
| Steps | Procedure |
|---|---|
| <p>1. Remove handle and valve cover</p> | <p>Remove the screws used for fixing the handle and valve cover, pull the handle and valve cover up ward to remove them.</p>  |
| <p>2. Remove top panel</p> | <p>Remove the screws fixing top panel and then remove the top panel.</p>  |
| <p>3. Remove front grille</p> | <p>Remove connection screws between the front grille and the front panel. Then remove the front grille.</p>  |

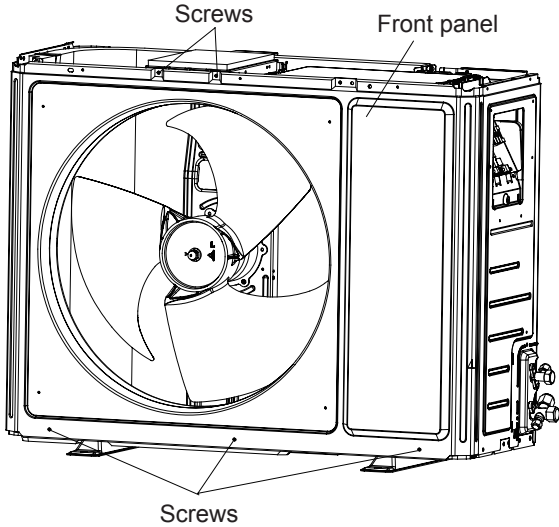
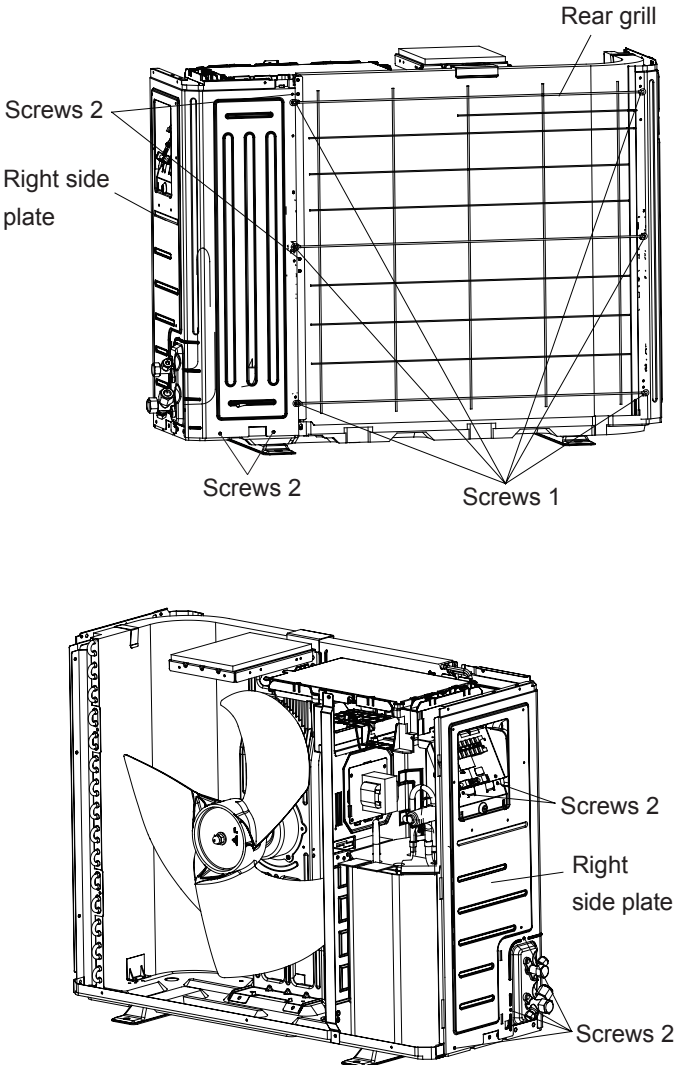
| Steps | Procedure |
|---|---|
| <p>4. Remove front panel</p> <p>Remove the screws connecting the front panel with the chassis and the motor support, and then remove the front panel.</p> |  |
| <p>5. Remove rear grill and right side plate</p> <p>Remove the screws 1 connecting the left side plate and right side plate and then remove rear grill.</p> <p>Remove the screws 2 connecting the right side plate with the chassis, the valve support and the electric box, and then remove the right side plate .</p> |  |

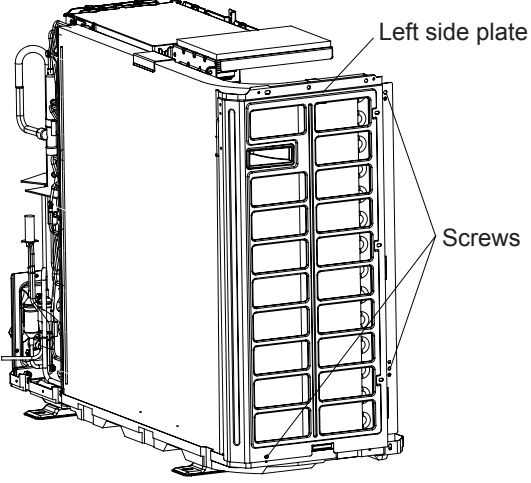
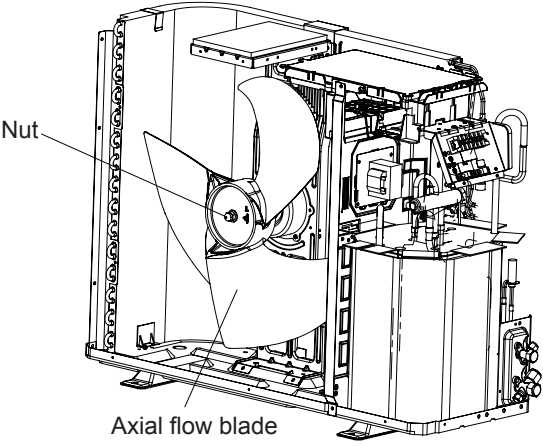
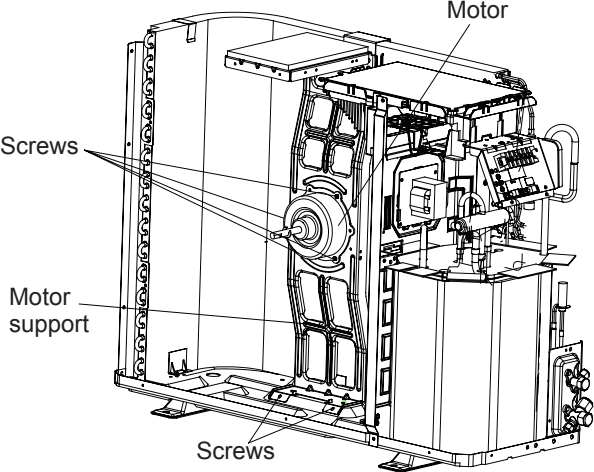
| Steps | Procedure |
|--|---|
| <p>6. Remove left side plate</p> | <p>Remove the screws connecting the left side plate and the chassis, and then remove the left side plate.</p>  |
| <p>7. Remove axial flow blade</p> | <p>Remove the nut fixing the blade and then remove the axial flow blade.</p>  |
| <p>8. Remove motor and motor support</p> | <p>Remove the screws fixing motor and then remove the motor. Remove the screws fixing motor support and then remove the motor support.</p>  |

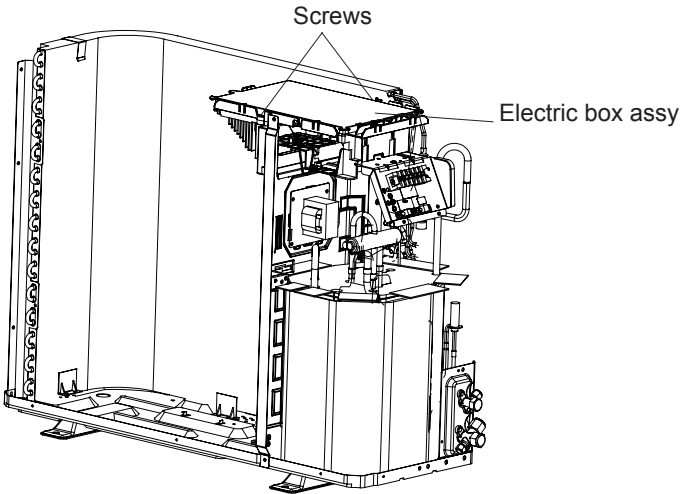
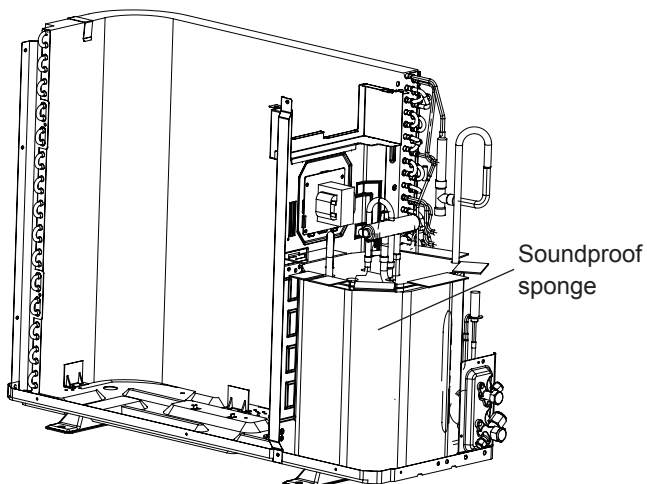
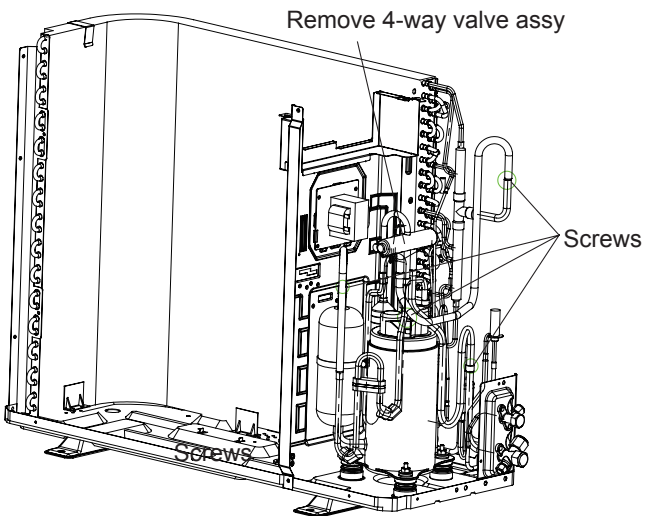
| Steps | Procedure |
|-------------------------------------|---|
| <p>9. Remove electric box assy</p> | <p>Remove the screws fixing electric box assy ; pull out each wiring terminal; lift the electric box assy upwards to remove it.</p> <p>Note: When pulling out the wiring terminal, pay attention to loose the clasp and don't pull it so hard.</p>  |
| <p>10. Remove soundproof sponge</p> | <p>Since the piping ports on the soundproof sponge are torn easily, remove the soundproof sponge carefully.</p>  |
| <p>11. Remove 4-way valve assy</p> | <p>Unsolder the spot weld of 4-way valve assy, compressor and condenser, and then remove the 4-way valve assy .</p> <p>Note: When unsoldering the spot weld, wrap the 4-way valve with wet cloth completely to avoid damaging the valve due to high temperature.</p>  |

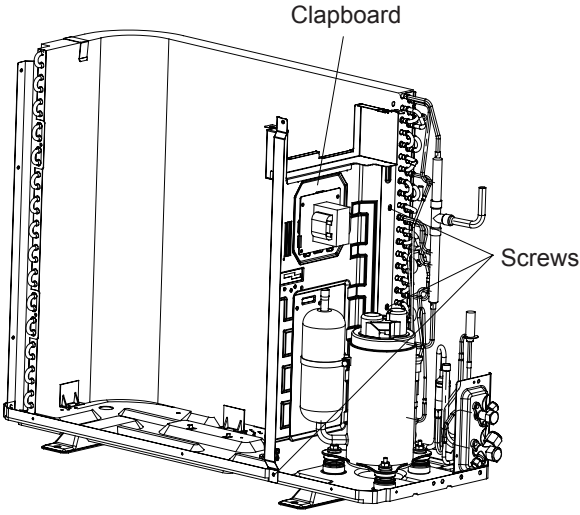
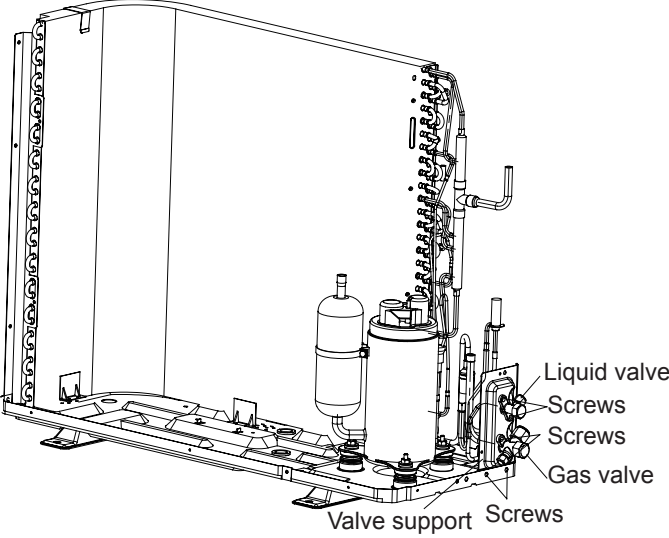
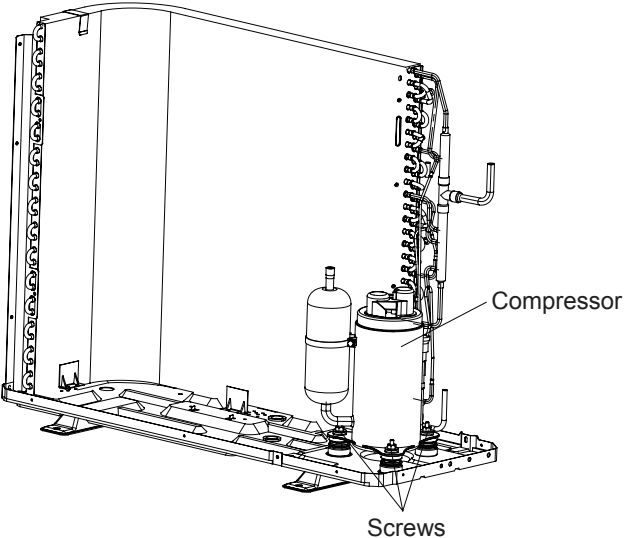
| Steps | Procedure |
|--|---|
| 12. Remove clapboard | <p>Remove the screws fixing clapboard and then remove the clapboard.</p>  |
| 13. Remove gas valve ,liquid valve and valve support | <p>Since the piping ports on the soundproof sponge are torn easily, remove the soundproof sponge carefully.</p>  |
| 14. Remove compressor | <p>Remove 3 foot nuts on compressor, and then remove the compressor.</p> <p>Note: Protect the ports of discharge pipe and suction pipe to avoid foreign objects to enter it.</p>  |

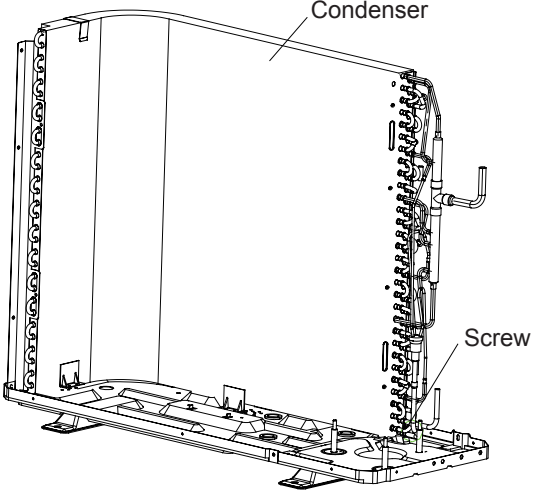
| Steps | Procedure |
|----------------------|---|
| 15. Remove condenser | |
| | <p data-bbox="224 323 665 388">Remove one screw fixing the condenser, then remove the condenser.</p>  |

Appendix:

Appendix 1: Reference Sheet of Celsius and Fahrenheit

Conversion formula for Fahrenheit degree and Celsius degree: $T_f = T_c \times 1.8 + 32$

Set temperature

| Fahrenheit display temperature (°F) | Fahrenheit (°F) | Celsius (°C) | Fahrenheit display temperature (°F) | Fahrenheit (°F) | Celsius (°C) | Fahrenheit display temperature (°F) | Fahrenheit (°F) | Celsius (°C) |
|-------------------------------------|-----------------|--------------|-------------------------------------|-----------------|--------------|-------------------------------------|-----------------|--------------|
| 61 | 60.8 | 16 | 69/70 | 69.8 | 21 | 78/79 | 78.8 | 26 |
| 62/63 | 62.6 | 17 | 71/72 | 71.6 | 22 | 80/81 | 80.6 | 27 |
| 64/65 | 64.4 | 18 | 73/74 | 73.4 | 23 | 82/83 | 82.4 | 28 |
| 66/67 | 66.2 | 19 | 75/76 | 75.2 | 24 | 84/85 | 84.2 | 29 |
| 68 | 68 | 20 | 77 | 77 | 25 | 86 | 86 | 30 |

Ambient temperature

| Fahrenheit display temperature (°F) | Fahrenheit (°F) | Celsius (°C) | Fahrenheit display temperature (°F) | Fahrenheit (°F) | Celsius (°C) | Fahrenheit display temperature (°F) | Fahrenheit (°F) | Celsius (°C) |
|-------------------------------------|-----------------|--------------|-------------------------------------|-----------------|--------------|-------------------------------------|-----------------|--------------|
| 32/33 | 32 | 0 | 55/56 | 55.4 | 13 | 79/80 | 78.8 | 26 |
| 34/35 | 33.8 | 1 | 57/58 | 57.2 | 14 | 81 | 80.6 | 27 |
| 36 | 35.6 | 2 | 59/60 | 59 | 15 | 82/83 | 82.4 | 28 |
| 37/38 | 37.4 | 3 | 61/62 | 60.8 | 16 | 84/85 | 84.2 | 29 |
| 39/40 | 39.2 | 4 | 63 | 62.6 | 17 | 86/87 | 86 | 30 |
| 41/42 | 41 | 5 | 64/65 | 64.4 | 18 | 88/89 | 87.8 | 31 |
| 43/44 | 42.8 | 6 | 66/67 | 66.2 | 19 | 90 | 89.6 | 32 |
| 45 | 44.6 | 7 | 68/69 | 68 | 20 | 91/92 | 91.4 | 33 |
| 46/47 | 46.4 | 8 | 70/71 | 69.8 | 21 | 93/94 | 93.2 | 34 |
| 48/49 | 48.2 | 9 | 72 | 71.6 | 22 | 95/96 | 95 | 35 |
| 50/51 | 50 | 10 | 73/74 | 73.4 | 23 | 97/98 | 96.8 | 36 |
| 52/53 | 51.8 | 11 | 75/76 | 75.2 | 24 | 99 | 98.6 | 37 |
| 54 | 53.6 | 12 | 77/78 | 77 | 25 | | | |

Appendix 2: Configuration of Connection Pipe

- Standard length of connection pipe
 - 5m, 7.5m, 8m.
- Min. length of connection pipe is 3m.
- Max. length of connection pipe and max. high difference. (More details please refer to the specifications.)
- The additional refrigerant oil and refrigerant charging required after prolonging connection pipe
 - After the length of connection pipe is prolonged for 10m at the basis of standard length, you should add 5ml of refrigerant oil for each additional 5m of connection pipe.
 - The calculation method of additional refrigerant charging amount (on the basis of liquid pipe):
 - When the length of connection pipe is above 5m, add refrigerant according to the prolonged length of liquid pipe. The additional refrigerant charging amount per meter is different according to the diameter of liquid pipe. See the following sheet.
 - Additional refrigerant charging amount = prolonged length of liquid pipe X additional refrigerant charging amount per meter

| Additional refrigerant charging amount for R22, R407C, R410A and R134a | | | |
|--|----------------|-----------------------|--------------------------|
| Diameter of connection pipe | | Outdoor unit throttle | |
| Liquid pipe(mm) | Gas pipe(mm) | Cooling only(g/m) | Cooling and heating(g/m) |
| Φ6 | Φ9.5 or Φ12 | 15 | 20 |
| Φ6 or Φ9.5 | Φ16 or Φ19 | 15 | 50 |
| Φ12 | Φ19 or Φ22.2 | 30 | 120 |
| Φ16 | Φ25.4 or Φ31.8 | 60 | 120 |
| Φ19 | / | 250 | 250 |
| Φ22.2 | / | 350 | 350 |

Appendix 3: Pipe Expanding Method

⚠ Note:

Improper pipe expanding is the main cause of refrigerant leakage. Please expand the pipe according to the following steps:

A: Cut the pip

- Confirm the pipe length according to the distance of indoor unit and outdoor unit.
- Cut the required pipe with pipe cutter.

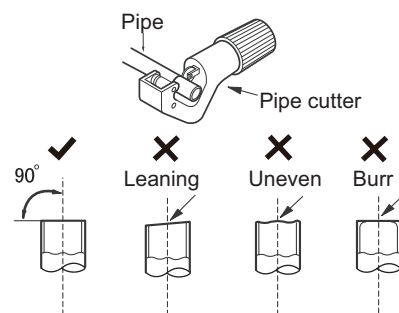

B: Remove the burrs

- Remove the burrs with shaper and prevent the burrs from getting into the pipe.

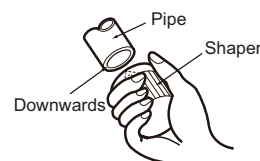

C: Put on suitable insulating pipe

D: Put on the union nut

- Remove the union nut on the indoor connection pipe and outdoor valve; install the union nut on the pipe.

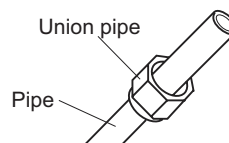

E: Expand the port

- Expand the port with expander.

⚠ Note:

- "A" is different according to the diameter, please refer to the sheet below:

| Outer diameter(mm) | A(mm) | |
|--------------------|-------|-----|
| | Max | Min |
| Φ6 - 6.35 (1/4") | 1.3 | 0.7 |
| Φ9.52 (3/8") | 1.6 | 1.0 |
| Φ12 - 12.70 (1/2") | 1.8 | 1.0 |
| Φ16 - 15.88 (5/8") | 2.4 | 2.2 |

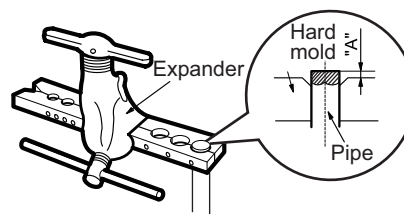

F: Inspection

- Check the quality of expanding port. If there is any blemish, expand the port again according to the steps above.

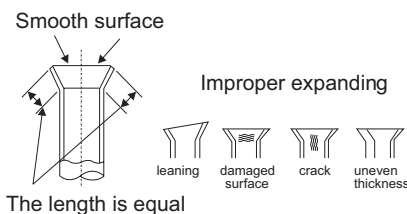

Appendix 4: List of Resistance for Temperature Sensor

Resistance Table of Ambient Temperature Sensor for Indoor and Outdoor Units(15K)

| Temp(°C) | Resistance(kΩ) | Temp(°C) | Resistance(kΩ) | Temp(°C) | Resistance(kΩ) | Temp(°C) | Resistance(kΩ) |
|----------|----------------|----------|----------------|----------|----------------|----------|----------------|
| -19 | 138.1 | 20 | 18.75 | 59 | 3.848 | 98 | 1.071 |
| -18 | 128.6 | 21 | 17.93 | 60 | 3.711 | 99 | 1.039 |
| -17 | 121.6 | 22 | 17.14 | 61 | 3.579 | 100 | 1.009 |
| -16 | 115 | 23 | 16.39 | 62 | 3.454 | 101 | 0.98 |
| -15 | 108.7 | 24 | 15.68 | 63 | 3.333 | 102 | 0.952 |
| -14 | 102.9 | 25 | 15 | 64 | 3.217 | 103 | 0.925 |
| -13 | 97.4 | 26 | 14.36 | 65 | 3.105 | 104 | 0.898 |
| -12 | 92.22 | 27 | 13.74 | 66 | 2.998 | 105 | 0.873 |
| -11 | 87.35 | 28 | 13.16 | 67 | 2.896 | 106 | 0.848 |
| -10 | 82.75 | 29 | 12.6 | 68 | 2.797 | 107 | 0.825 |
| -9 | 78.43 | 30 | 12.07 | 69 | 2.702 | 108 | 0.802 |
| -8 | 74.35 | 31 | 11.57 | 70 | 2.611 | 109 | 0.779 |
| -7 | 70.5 | 32 | 11.09 | 71 | 2.523 | 110 | 0.758 |
| -6 | 66.88 | 33 | 10.63 | 72 | 2.439 | 111 | 0.737 |
| -5 | 63.46 | 34 | 10.2 | 73 | 2.358 | 112 | 0.717 |
| -4 | 60.23 | 35 | 9.779 | 74 | 2.28 | 113 | 0.697 |
| -3 | 57.18 | 36 | 9.382 | 75 | 2.206 | 114 | 0.678 |
| -2 | 54.31 | 37 | 9.003 | 76 | 2.133 | 115 | 0.66 |
| -1 | 51.59 | 38 | 8.642 | 77 | 2.064 | 116 | 0.642 |
| 0 | 49.02 | 39 | 8.297 | 78 | 1.997 | 117 | 0.625 |
| 1 | 46.6 | 40 | 7.967 | 79 | 1.933 | 118 | 0.608 |
| 2 | 44.31 | 41 | 7.653 | 80 | 1.871 | 119 | 0.592 |
| 3 | 42.14 | 42 | 7.352 | 81 | 1.811 | 120 | 0.577 |
| 4 | 40.09 | 43 | 7.065 | 82 | 1.754 | 121 | 0.561 |
| 5 | 38.15 | 44 | 6.791 | 83 | 1.699 | 122 | 0.547 |
| 6 | 36.32 | 45 | 6.529 | 84 | 1.645 | 123 | 0.532 |
| 7 | 34.58 | 46 | 6.278 | 85 | 1.594 | 124 | 0.519 |
| 8 | 32.94 | 47 | 6.038 | 86 | 1.544 | 125 | 0.505 |
| 9 | 31.38 | 48 | 5.809 | 87 | 1.497 | 126 | 0.492 |
| 10 | 29.9 | 49 | 5.589 | 88 | 1.451 | 127 | 0.48 |
| 11 | 28.51 | 50 | 5.379 | 89 | 1.408 | 128 | 0.467 |
| 12 | 27.18 | 51 | 5.197 | 90 | 1.363 | 129 | 0.456 |
| 13 | 25.92 | 52 | 4.986 | 91 | 1.322 | 130 | 0.444 |
| 14 | 24.73 | 53 | 4.802 | 92 | 1.282 | 131 | 0.433 |
| 15 | 23.6 | 54 | 4.625 | 93 | 1.244 | 132 | 0.422 |
| 16 | 22.53 | 55 | 4.456 | 94 | 1.207 | 133 | 0.412 |
| 17 | 21.51 | 56 | 4.294 | 95 | 1.171 | 134 | 0.401 |
| 18 | 20.54 | 57 | 4.139 | 96 | 1.136 | 135 | 0.391 |
| 19 | 19.63 | 58 | 3.99 | 97 | 1.103 | 136 | 0.382 |

Resistance Table of Tube Temperature Sensors for Outdoor and Indoor(20K)

| Temp(°C) | Resistance(kΩ) | Temp(°C) | Resistance(kΩ) | Temp(°C) | Resistance(kΩ) | Temp(°C) | Resistance(kΩ) |
|----------|----------------|----------|----------------|----------|----------------|----------|----------------|
| -19 | 181.4 | 20 | 25.01 | 59 | 5.13 | 98 | 1.427 |
| -18 | 171.4 | 21 | 23.9 | 60 | 4.948 | 99 | 1.386 |
| -17 | 162.1 | 22 | 22.85 | 61 | 4.773 | 100 | 1.346 |
| -16 | 153.3 | 23 | 21.85 | 62 | 4.605 | 101 | 1.307 |
| -15 | 145 | 24 | 20.9 | 63 | 4.443 | 102 | 1.269 |
| -14 | 137.2 | 25 | 20 | 64 | 4.289 | 103 | 1.233 |
| -13 | 129.9 | 26 | 19.14 | 65 | 4.14 | 104 | 1.198 |
| -12 | 123 | 27 | 18.13 | 66 | 3.998 | 105 | 1.164 |
| -11 | 116.5 | 28 | 17.55 | 67 | 3.861 | 106 | 1.131 |
| -10 | 110.3 | 29 | 16.8 | 68 | 3.729 | 107 | 1.099 |
| -9 | 104.6 | 30 | 16.1 | 69 | 3.603 | 108 | 1.069 |
| -8 | 99.13 | 31 | 15.43 | 70 | 3.481 | 109 | 1.039 |
| -7 | 94 | 32 | 14.79 | 71 | 3.364 | 110 | 1.01 |
| -6 | 89.17 | 33 | 14.18 | 72 | 3.252 | 111 | 0.983 |
| -5 | 84.61 | 34 | 13.59 | 73 | 3.144 | 112 | 0.956 |
| -4 | 80.31 | 35 | 13.04 | 74 | 3.04 | 113 | 0.93 |
| -3 | 76.24 | 36 | 12.51 | 75 | 2.94 | 114 | 0.904 |
| -2 | 72.41 | 37 | 12 | 76 | 2.844 | 115 | 0.88 |
| -1 | 68.79 | 38 | 11.52 | 77 | 2.752 | 116 | 0.856 |
| 0 | 65.37 | 39 | 11.06 | 78 | 2.663 | 117 | 0.833 |
| 1 | 62.13 | 40 | 10.62 | 79 | 2.577 | 118 | 0.811 |
| 2 | 59.08 | 41 | 10.2 | 80 | 2.495 | 119 | 0.77 |
| 3 | 56.19 | 42 | 9.803 | 81 | 2.415 | 120 | 0.769 |
| 4 | 53.46 | 43 | 9.42 | 82 | 2.339 | 121 | 0.746 |
| 5 | 50.87 | 44 | 9.054 | 83 | 2.265 | 122 | 0.729 |
| 6 | 48.42 | 45 | 8.705 | 84 | 2.194 | 123 | 0.71 |
| 7 | 46.11 | 46 | 8.37 | 85 | 2.125 | 124 | 0.692 |
| 8 | 43.92 | 47 | 8.051 | 86 | 2.059 | 125 | 0.674 |
| 9 | 41.84 | 48 | 7.745 | 87 | 1.996 | 126 | 0.658 |
| 10 | 39.87 | 49 | 7.453 | 88 | 1.934 | 127 | 0.64 |
| 11 | 38.01 | 50 | 7.173 | 89 | 1.875 | 128 | 0.623 |
| 12 | 36.24 | 51 | 6.905 | 90 | 1.818 | 129 | 0.607 |
| 13 | 34.57 | 52 | 6.648 | 91 | 1.736 | 130 | 0.592 |
| 14 | 32.98 | 53 | 6.403 | 92 | 1.71 | 131 | 0.577 |
| 15 | 31.47 | 54 | 6.167 | 93 | 1.658 | 132 | 0.563 |
| 16 | 30.04 | 55 | 5.942 | 94 | 1.609 | 133 | 0.549 |
| 17 | 28.68 | 56 | 5.726 | 95 | 1.561 | 134 | 0.535 |
| 18 | 27.39 | 57 | 5.519 | 96 | 1.515 | 135 | 0.521 |
| 19 | 26.17 | 58 | 5.32 | 97 | 1.47 | 136 | 0.509 |

Resistance Table of Discharge Temperature Sensor for Outdoor(50K)

| Temp(°C) | Resistance(kΩ) | Temp(°C) | Resistance(kΩ) | Temp(°C) | Resistance(kΩ) | Temp(°C) | Resistance(kΩ) |
|----------|----------------|----------|----------------|----------|----------------|----------|----------------|
| -29 | 853.5 | 10 | 98 | 49 | 18.34 | 88 | 4.75 |
| -28 | 799.8 | 11 | 93.42 | 50 | 17.65 | 89 | 4.61 |
| -27 | 750 | 12 | 89.07 | 51 | 16.99 | 90 | 4.47 |
| -26 | 703.8 | 13 | 84.95 | 52 | 16.36 | 91 | 4.33 |
| -25 | 660.8 | 14 | 81.05 | 53 | 15.75 | 92 | 4.20 |
| -24 | 620.8 | 15 | 77.35 | 54 | 15.17 | 93 | 4.08 |
| -23 | 580.6 | 16 | 73.83 | 55 | 14.62 | 94 | 3.96 |
| -22 | 548.9 | 17 | 70.5 | 56 | 14.09 | 95 | 3.84 |
| -21 | 516.6 | 18 | 67.34 | 57 | 13.58 | 96 | 3.73 |
| -20 | 486.5 | 19 | 64.33 | 58 | 13.09 | 97 | 3.62 |
| -19 | 458.3 | 20 | 61.48 | 59 | 12.62 | 98 | 3.51 |
| -18 | 432 | 21 | 58.77 | 60 | 12.17 | 99 | 3.41 |
| -17 | 407.4 | 22 | 56.19 | 61 | 11.74 | 100 | 3.32 |
| -16 | 384.5 | 23 | 53.74 | 62 | 11.32 | 101 | 3.22 |
| -15 | 362.9 | 24 | 51.41 | 63 | 10.93 | 102 | 3.13 |
| -14 | 342.8 | 25 | 49.19 | 64 | 10.54 | 103 | 3.04 |
| -13 | 323.9 | 26 | 47.08 | 65 | 10.18 | 104 | 2.96 |
| -12 | 306.2 | 27 | 45.07 | 66 | 9.83 | 105 | 2.87 |
| -11 | 289.6 | 28 | 43.16 | 67 | 9.49 | 106 | 2.79 |
| -10 | 274 | 29 | 41.34 | 68 | 9.17 | 107 | 2.72 |
| -9 | 259.3 | 30 | 39.61 | 69 | 8.85 | 108 | 2.64 |
| -8 | 245.6 | 31 | 37.96 | 70 | 8.56 | 109 | 2.57 |
| -7 | 232.6 | 32 | 36.38 | 71 | 8.27 | 110 | 2.50 |
| -6 | 220.5 | 33 | 34.88 | 72 | 7.99 | 111 | 2.43 |
| -5 | 209 | 34 | 33.45 | 73 | 7.73 | 112 | 2.37 |
| -4 | 198.3 | 35 | 32.09 | 74 | 7.47 | 113 | 2.30 |
| -3 | 199.1 | 36 | 30.79 | 75 | 7.22 | 114 | 2.24 |
| -2 | 178.5 | 37 | 29.54 | 76 | 7.00 | 115 | 2.18 |
| -1 | 169.5 | 38 | 28.36 | 77 | 6.76 | 116 | 2.12 |
| 0 | 161 | 39 | 27.23 | 78 | 6.54 | 117 | 2.07 |
| 1 | 153 | 40 | 26.15 | 79 | 6.33 | 118 | 2.02 |
| 2 | 145.4 | 41 | 25.11 | 80 | 6.13 | 119 | 1.96 |
| 3 | 138.3 | 42 | 24.13 | 81 | 5.93 | 120 | 1.91 |
| 4 | 131.5 | 43 | 23.19 | 82 | 5.75 | 121 | 1.86 |
| 5 | 125.1 | 44 | 22.29 | 83 | 5.57 | 122 | 1.82 |
| 6 | 119.1 | 45 | 21.43 | 84 | 5.39 | 123 | 1.77 |
| 7 | 113.4 | 46 | 20.6 | 85 | 5.22 | 124 | 1.73 |
| 8 | 108 | 47 | 19.81 | 86 | 5.06 | 125 | 1.68 |
| 9 | 102.8 | 48 | 19.06 | 87 | 4.90 | 126 | 1.64 |

JF00303263



GREE ELECTRIC APPLIANCES,INC.OF ZHUHAI

Add: West Jinji Rd, Qianshan, Zhuhai, Guangdong, China 519070

Tel: (+86-756) 8522218 Fax: (+86-756) 8669426

Email: gree@gree.com.cn Http://www.gree.com

HONG KONG GREE ELECTRIC APPLIANCES SALES LIMITED

Add: Unit 2612,26/F.,Miramar Tower 132 Nathan Road,TST,Kowloon,HK

Tel: (852) 31658898 Fax: (852) 31651029

For product improvement, specifications and appearance in this manual are subject to change without prior notice.